

INSTRUCTION MANUAL

REGULATED DC POWER SUPPLY

MODELS PAL16-40/PAL35-20

KIKUSUI ELECTRONICS CORPORATION

M-94091

198.9

~~83-7-20~~

833575C

Power Requirements of this Product

Power requirements of this product have been changed and the relevant sections of the Operation Manual should be revised accordingly.

(Revision should be applied to items indicated by a check mark)

Input voltage

The input voltage of this product is _____ VAC,
and the voltage range is _____ to _____ VAC. Use the product within this range only.

Input fuse

The rating of this product's input fuse is _____ A, _____ VAC, and _____.

WARNING

- To avoid electrical shock, always disconnect the AC power cable or turn off the switch on the switchboard before attempting to check or replace the fuse.
- Use a fuse element having a shape, rating, and characteristics suitable for this product. The use of a fuse with a different rating or one that short circuits the fuse holder may result in fire, electric shock, or irreparable damage.

AC power cable

The product is provided with AC power cables described below. If the cable has no power plug, attach a power plug or crimp-style terminals to the cable in accordance with the wire colors specified in the drawing.

WARNING

- The attachment of a power plug or crimp-style terminals must be carried out by qualified personnel.

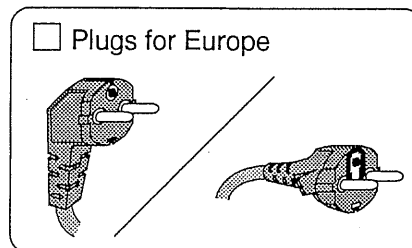
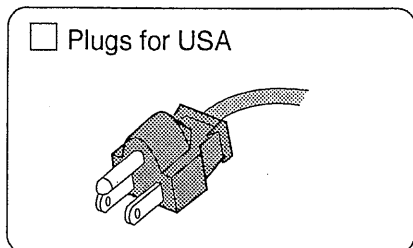
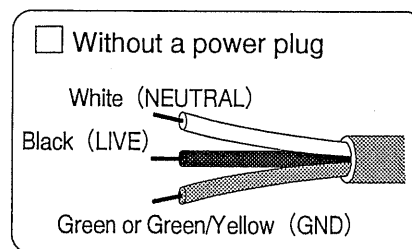
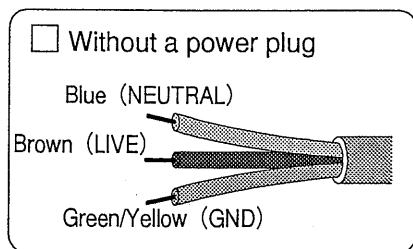

Provided by Kikusui agents
Kikusui agents can provide you with suitable AC power cable.
For further information, contact your Kikusui agent.

Another Cable _____

TABLE OF CONTENTS

	<u>PAGE</u>
SECTION 1. GENERAL	1
1-1. Description	1
1-2. Specifications	3
* Power Consumption Charts	6
* Mechanical Outline Drawing	7
SECTION 2. OPERATION	8
2-1. Precautions for Operation	8
2-2. Inhibition of Modification for AC Line Voltage Change	13
2-3. Description of Panel Items	15
2-4. Operating Procedures	19
SECTION 3. PROTECTORS	23
3-1. Description	23
3-2. Description of Protective Circuits	23
3-3. Operation Method of Overvoltage Protector	25
SECTION 4. APPLICATIONS	27
4-1. Remote Sensing	27
4-2. ON/OFF-control of Output	28
4-3. Remote Control of Output Voltage	31
4-4. Remote Control of Output Current	39
4-5. Series Operation and Parallel Operation	48
4-6. One-control Parallel Operation	50
4-7. One-control Series Operation	51
4-8. Constant-current Charge/Discharge Operation	54
SECTION 5. MAINTENANCE	58
5-1. Inspection	58
5-2. Meter Calibration and Adjustment	59
* Block Diagram	63

833578

SECTION 1. GENERAL

1-1. Description

- o The PAL Series Regulated DC Power Supplies are variable constant-voltage constant-current power supplies. They are featured with a switching regulator system for compactness and a series regulator system for high performance.

As compared with the conventional types of power supplies which employ large and heavy AC power transformers and choke coils, the PAL Series Power Supplies are light (approximately a half in weight, as compared with other types of power supplies of equivalent ratings of own manufacture). Although they employ a switching system, their outputs contain less ripples, their output impedances are low, and they provide excellent temperature coefficients. Thus, they can be used as general-purpose power supplies for various applications.

- o Features of PAL Series Power Supplies

1. Output switch:

The output can be ON/OFF-controlled from the front panel, without generating chattering noise (electronic switch).

2. Preset OVP (overvoltage protector):

The preset OVP voltage is indicated on the voltmeter without pausing the protective function, facilitating setting and monitoring of the trip voltage. If the output voltage exceeds the preset voltage, the power switch cuts off, the oscillation stops instantaneously and the series control transistor cuts off to protect the load.

3. Current/voltage limit switch:

The crossover point between the constant voltage (CV) mode and the constant current (CC) mode is indicated by the meters. (The voltmeter indicates the preset CV value and the ammeter indicates the preset CC value.) When the output is off, the switch can be used for presetting.

- o The PAL Series Power Supplies are incorporated with the various protective provisions, such as the preset OVP circuit, overheat protection circuit, internal voltage detector circuit, thermal fuse, input fuse, and rush input current suppression circuit.
- o When the allowable voltage range of the load is narrow and the load may be damaged even with a slight overvoltage (such as a semiconductor load), a high-speed OVP circuit can be incorporated. (The instrument which is incorporated with this optional thyristor-type high-speed OVP circuit is identified with a symbol "P" suffixed at the end of the model number.)
- o The instrument is housed in a bench-top type casing. It also can be installed on an EIA Standard rack or an JIS Standard rack, by using the mounting brackets.

Note: Before starting using the instrument, be sure to thoroughly read this instruction manual. If you have any questions regarding the operation method of this instrument, please consult your Kikusui agent.

933578

1-2. Specifications

Model	PAL 16-40	PAL 35-20
Input		
Input Supply	<input type="checkbox"/> 120 V $\pm 10\%$, 50/60 Hz AC, 1 ϕ <input type="checkbox"/> 240 V $\pm 10\%$, 50/60 Hz AC, 1 ϕ	
Power consumption (120 VAC, rated load)	Approx. 1.5 kVA	Approx. 1.5 kVA
Output		
Output voltage range (10 turns)	0 - 16 V	0 - 35 V
Voltage resolution (theoretical value)	3 mV	6 mV
Output current range (1 turn)	0 - 40 A	0 - 20 A
Current resolution (theoretical value)	100 mA	50 mA
Constant voltage characteristics		
Regulation *1		
Source effect (Line regulation) (For $\pm 10\%$ change of line voltage)	1 mV	1 mV
Load effect (Load regulation) (For 0 to 100% change of output current)	2 mV	2 mV
Ripple and noise *2		
[rms] (5 Hz - 1 MHz)	1 mVrms	500 μ Vrms
[p-p] (DC - 10 MHz) (Typical)	10 mVp-p	10 mVp-p
Transient response *3		
5 - 100% (typical)	50 μ sec	
Temperature coefficient (typical)		
	50 ppm/ $^{\circ}$ C	
Remote control, voltage to output voltage ratio	Approx. 10 V to 16 V	Approx. 10 V to 35 V
Remote control, resistance to output voltage ratio	Approx. 10 k Ω to 16 V	Approx. 10 k Ω to 35 V
Remote control, current to output voltage ratio	Approx. 1 mA to 16 V	Approx. 1 mA to 35 V

- (Notes) *1: Measured using the sensing terminals.
 *2: Measured with the positive or negative output grounded.
 *3: Recovery time to within 0.05% + 10 mV of the output voltage.

823579-1
 44111-20

Model	PAL 16-40	PAL 35-20
Constant current characteristics		
Regulation		
Source effect (Line regulation) (For +10% change of line voltage)	3 mA	3 mA
Load effect (Load regulation) (For 0 to 100% change of Output voltage)	5 mA	5 mA
Ripple and noise *2 rms (5 Hz - 1 MHz)	10 mA	5 mA
Remote control, voltage to output current ratio	Approx. 10 V to 40 A	Approx. 10 V to 20 A
Remote control, resistance to output current ratio	Approx. 1 k Ω to 40 A	Approx. 1 k Ω to 20 A
Remote control, current to output current ratio	Approx. 0.4 mA to 40 A	Approx. 0.7 mA to 20 A
Operating ambient temperature range	0°C - 40°C (32°F - 104°F)	
Operating ambient humidity range	10% - 90% RH	
Cooling method	Forced air cooling with fan	
Polarity of output voltage	Positive or negative grounded	
Isolation from ground	+250V DC	
Protections		
Overvoltage protection (OVP)		
Voltage setting range *4	3 - 18 V	3 - 38 V
Trigger pulse width *4	50 msec	50 msec
Protective actions	Oscillation stops. Series control transistor cuts off. Power switch cuts off.	
Overheat protection (OHP)		
Trip temperature of thermal protector	85°C (185°F)	
Protective actions	Oscillation stops. Series control transistor cuts off. Power switch cuts off.	
Input fuse rating		
For 120 VAC source	20 A	20 A
For 240 VAC source	15 A	15 A
Thermal fuse rating (at sub-transformer)	135°C (275°F)	

(Note) *4: Typical value

PAL 16-40/35-20

833580

Model	PAL 16-40	PAL 35-20
Meters (full scale)		
DC voltmeter (2.5% of full scale)	16 V F.S	35 V F.S
DC ammeter (2.5% of full scale)	40 A F.S	22 A F.S
Constant voltage mode indication	C.V: with green LED	
Constant current mode indication	C.C: with red LED	
Insulation resistances *5		
Between chassis and line	500V DC more than 30M Ω	
Between chassis and output terminal	500V DC more than 20M Ω	
Dimensions	210 W x 130 H x 410 D mm (8.27 W x 5.12 H x 16.14 D in.)	
Maximum dimensions	230 W x 145 H x 465 D mm (9.06 W x 5.71 H x 18.31 D in.)	
Rack mounting		
JIS Std. (mm rack)	With RMF 4M and B23	
EIA Std. (in. rack)	With RMF 4 and B23	
Weight	Approx. 11.5 kg (25 lbs)	
Accessories (in carton)		
Instruction manual	1 copy	
Input line fuses (spares)		
For 120 VAC 20 A or For 240 VAC 15 A	1 ea.	
Guard caps	1 set	
Input cord	3-core cable with a ground wire, 3.5 square-mm, approx. 3 m (9.8 ft.) long	

(Note) *5: With ambient humidity not higher than 70% RH.

2011/11/25

800581

PAL 35-20 Power consumption 50 Hz, 100 V

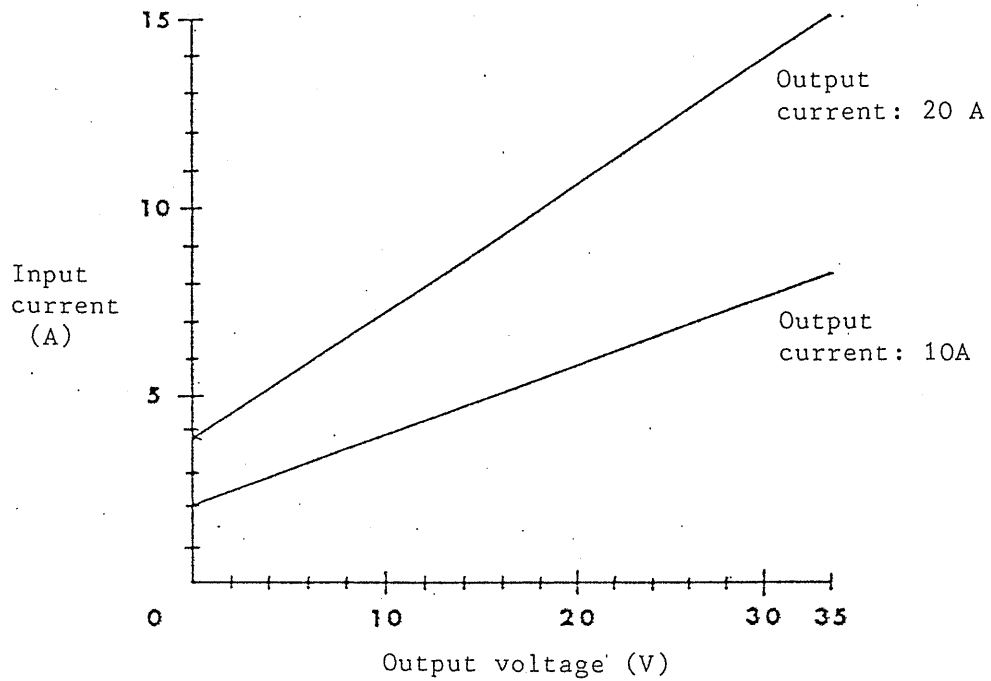

PAL 16-40 Power consumption 50 Hz, 100 V

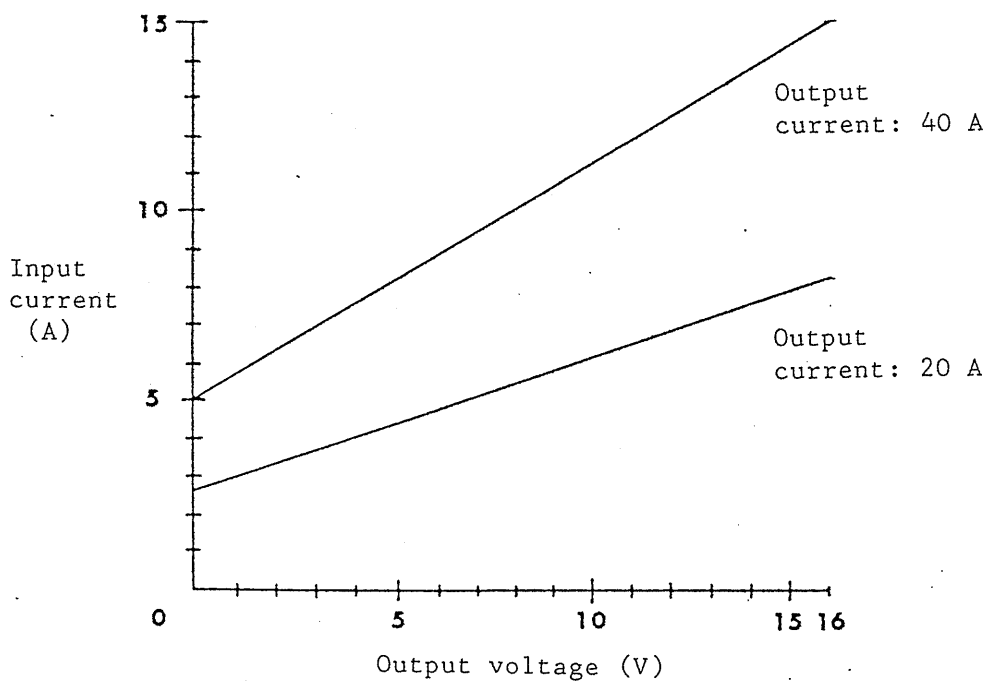

833582

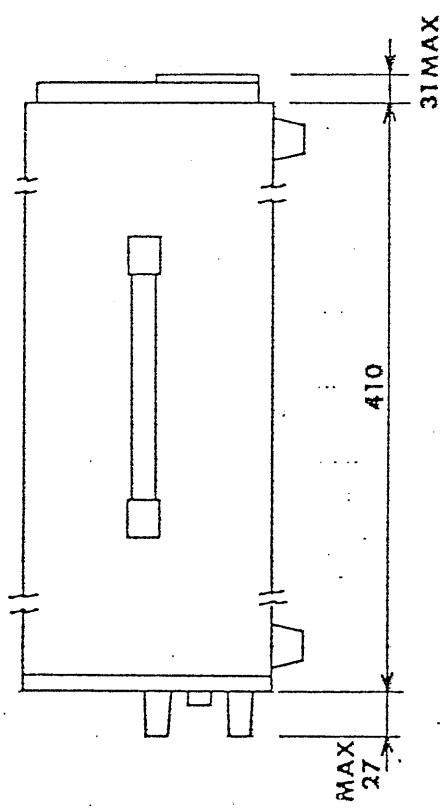
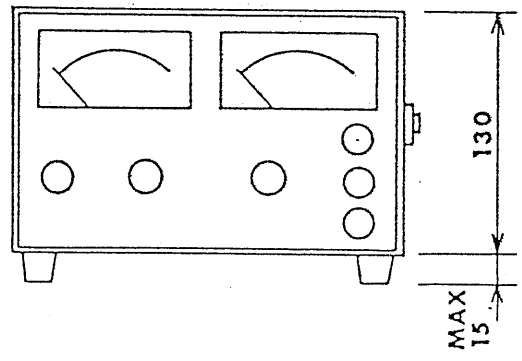
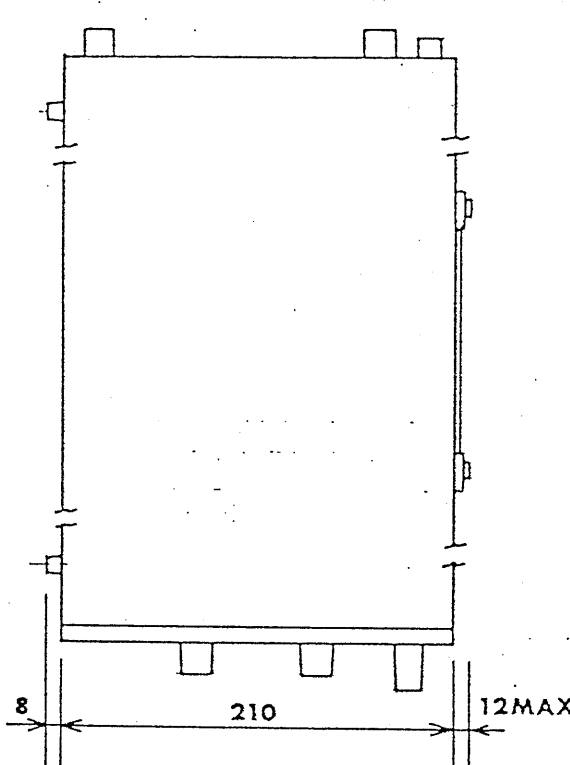
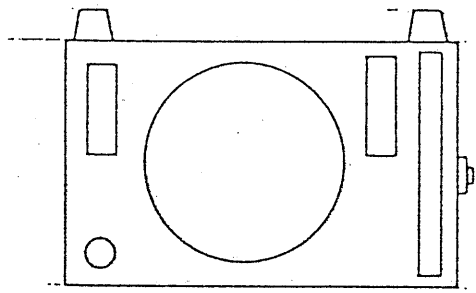

Mechanical Outline Drawing

889598
889598

SECTION 2. OPERATION

2-1. Precautions for Operation (Installation)

1. Input power

- o The input voltage range is 120 V $\pm 10\%$ (108 V - 132 V) (*or 240 V $\pm 10\%$ (216 V - 264 V)), 48 - 62 Hz single-phase AC.
(*: For the 240 VAC model)
- o The input power fuse rating is
20 A for 120 VAC model or
*15 A for 240 VAC model.
- o For current consumption, see the current consumption charts.

2. Rush current

- o The rush current which flows when the power is turned on is as follows:
 - 120 VAC model: Approx. 100 A peak or less, half-current period approx. 3 msec
 - 240 VAC model: Approx. 110 A peak or less, half-current period approx. 3 msec

3. Power cord

- o The input power cable which accompanies the power supply is a 3-core cable, with the nominal sectional area of each of the cores 3.5 mm^2 . When using a cable other than the accompanying one, it must be of an equivalent type (3-core cable, with core size 3.5 mm^2 or larger).

CAUTION: In order to prevent electric shock hazards, be sure to connect the ground line of the input power cable to an earth line.

8712.9

233504A

4. Output

- o Make sure that the jumpers of the terminal blocks on the rear panel are securely connected as shown in Figure 2-1 (when in the standard operation).

Figure 2-1

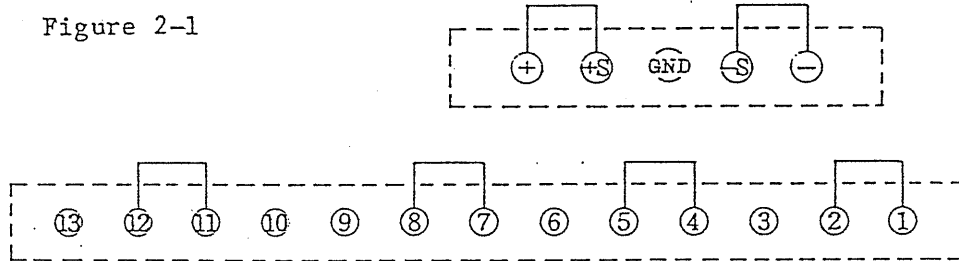

- o Normally, connect either one of the output terminals to the GND terminal with the shorting bar.

5. Ambient temperature

- o The ambient temperature range for the power supply to satisfy the specification performances is 0°C to 40°C (32°F to 104°F). The power supply should be used within this range.
- o If the power supply is operated at a high ambient temperature, the internal temperature detector circuit trips and the input power switch is turned off. If this has happened, cool it and then turn on the power again. There is an exponential relationship between ambient temperature and semiconductor life, electrolytic capacitor life and transformer insulation life. Note that components are rapidly deteriorated at high temperatures. It is important not to operate the power supply at an abnormally high ambient temperature also from the viewpoint of its life.
- o If the power supply is used at a temperature lower than -10°C (14°F) its operation may become unstable. Do not use the power supply at temperatures lower than this limit.

800585

6. Place for use

- o Place the power supply as apart as possible from the plating shop or other electrolytic processing shop and control the power supply output in the remote control mode.
- o Pay attention so that the ventilation ports (top, sides and bottom) and the fan air outlet are not blocked.
- o Provide a clearance of 30 cm or over from the fan air outlet.
- o Do not use the power supply in a highly humid or dusty atmosphere since such will cause operation failures and reliability degradation.
- o Install the power supply in a place where is reasonably free from vibration.
- o Do not use the power supply in a corrosive atmosphere, such as in thick mist of sulfuric acid.

7. Wires for output connections

- o For connecting the output to a load, use wires of a sufficient current rating referring to Table 2-1. If wires of an insufficient current rating is used, the voltage at the load may become unstable due to voltage drop in the wires, or the wires may be overheated in an extreme case.

982088

Table 2-1. Wire gauges and current ratings

Ta: 30°C (86°F)

Nominal cross section	Maximum current recommended by Kikusui	Maximum current designated by Electrical Installation Technical Ordinance (Article 29) JAPAN
2 mm ²	10 A	27 A
5.5 mm ²	20 A	49 A
8 mm ²	30 A	61 A
14 mm ²	50 A	88 A
22 mm ²	80 A	115 A
38 mm ²	100 A	162 A
80 mm ²	200 A	257 A
150 mm ²	300 A	395 A

8. Note for load

Note that the output may become unstable depending on the characteristics of loads as follows:

- (a) When the load current has peaks or it is of a pulse waveform:

Since the ammeter is of an average-value indication type, even when the meter reading is not higher than the preset value, the peak values may exceed the preset value and the operation may be driven instantaneously into the constant-current domain and the output voltage may fall. Observing carefully, it can be seen that the constant-current indicator lamp becomes dim.

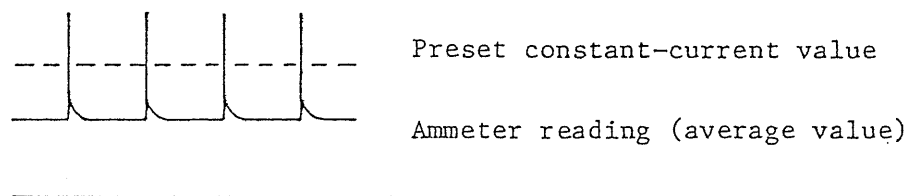

Figure 2-2. Load current with peaks

8003507

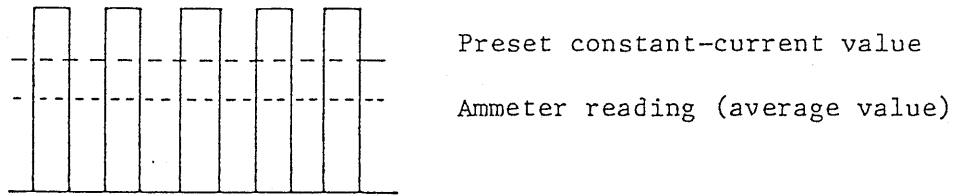

Figure 2-3. Load current of pulse waveform

In the above cases, the preset current value should be raised or the current rating should be increased.

(b) When the load is regenerative:

When a regenerative load (such as inverter, converter, or transformer) is connected to the power supply, as it cannot absorb the reverse current fed from the load, the output voltage increases and becomes unstable. In such a case, connect a bypass resistor as shown in Figure 2-4 to absorb the reverse current. The resistance of the bypass resistor can be calculated as follows:

$$R_D [\Omega] \leq \frac{E_o [V]}{I_{RP} [A]}$$

where, R_D : Dummy load (bypass resistor) to absorb reverse current

E_o : Output voltage

I_{RP} : Maximum reverse current

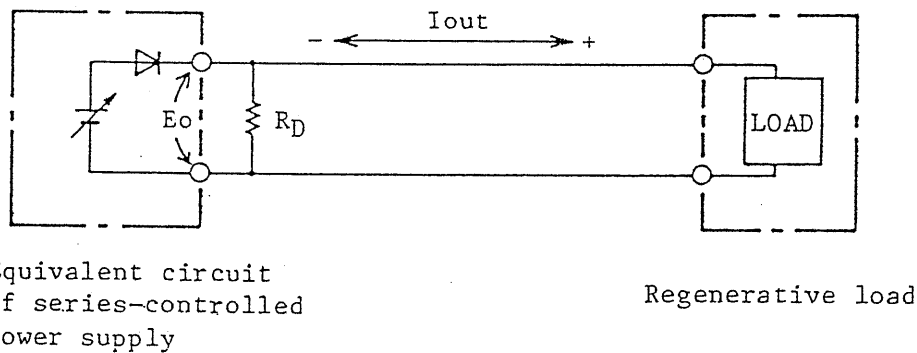

Figure 2-4

88990000

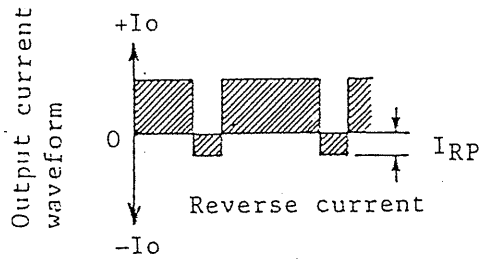

Figure 2-5

9. Guard caps

With the guard caps (accessories), the voltage and current control potentiometers can be fixed or semi-fixed as shown in Figure 2-4. The guard caps may be used when installing the power supply as a permanent component of a system equipment or when using it as a fixed-output power supply.

Note: When the power supply is operated in the external voltage control mode, the potentiometers on the front panel are used as full-scale adjustment potentiometers. In this case, be sure to protect them with the guard caps.

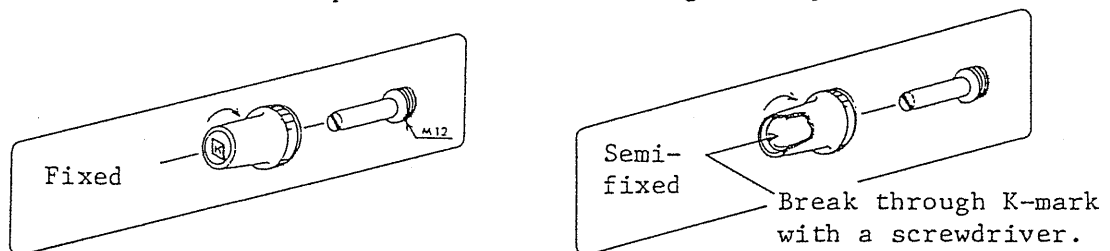

Figure 2-6

2-2. Inhibition of Modification for AC Line Voltage Change

WARNING: DO NOT ATTEMPT TO MODIFY THE POWER SUPPLIES BETWEEN 120-VAC TYPE AND 240-VAC TYPE.

The PAL Series Power Supplies are available as a 120-VAC type or a 240-VAC type. Modifications between them involves tasks which are more than can be handled by the user for himself. They involves modifications of fan motors and new installation of surge absorbers. When such modifications are needed, please order your Kikusui agent.

0000000000

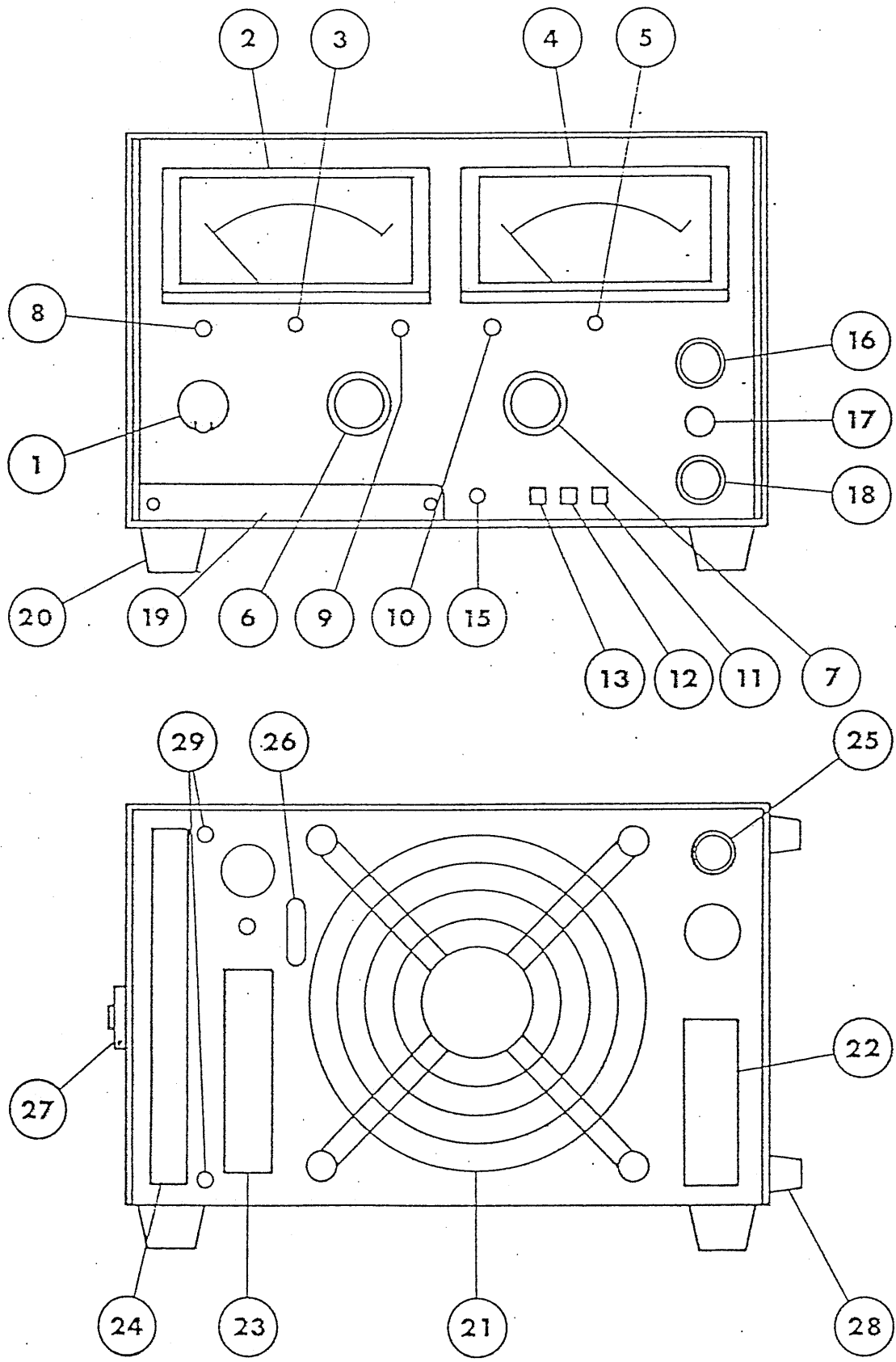

Figure 2-7

00
33
02
10
00

2-3. Description of Panel Items

① POWER switch:

For ON/OFF-control of the input power. As you throw this switch to the ON position (upper position), the input power is turned on and the power indicator lamp lights.

Note: When any one of the internal protectors (overvoltage protector, voltage detector, current detector, and temperature detector) has tripped, this switch is automatically turned off. Once it has been turned off, it cannot be immediately turned on. Wait about 5 seconds before turning on the switch again. Be sure to eliminate the cause of switch trip before turning on the switch again.

② Ammeter

Indicates the output current. Accuracy is 2.5% of FS.

③ Zero adjustment of ammeter

For zero-point adjustment of ammeter.

④ Voltmeter

Indicates the output voltage. Accuracy is 2.5% of FS.

⑤ Zero adjustment of voltmeter

For zero-point adjustment of voltmeter

⑥ Current setting knob

To set the output current for constant-current mode of operation. 1-turn potentiometer.

833591
160000

⑦ Voltage setting knob

To set the output voltage for constant-voltage mode of operation. 10-turn potentiometer.

⑧ Power indicator lamp

Indicates that the input power of the power supply is on.

⑨ C.C. (constant-current operation indicator lamp)

Indicates that the power supply is operating in the constant-current mode.

⑩ C.V. (constant-voltage operation indicator lamp)

Indicates that the power supply is operating in the constant-voltage mode.

⑪ OUTPUT ON/OFF switch

For ON/OFF-control of the output power. An electronic switch of excellent longevity, without generating chattering or other noise.

Note: The switch is not for mechanical turning on or off of the output circuit. Note that the output circuit is electrically connected even when the switch is OFF.

⑫ CUR/VOLT LIMIT (current/voltage limit switch)

When this switch is pressed, the voltmeter indicates the preset constant-voltage value and the ammeter indicates the preset constant-current value.

When the OUTPUT switch is set in the OFF state, presetting of the constant-voltage or constant-current value can be done by using this switch.

⑬ OVP preset switch (OVP: Overvoltage protector)

As you press this button, the voltmeter indicates the preset OVP voltage. By pressing this button, the preset OVP voltage can be checked without causing any effect on the output or without affecting the protective features.

⑮ OVP potentiometer

Keeping depressed the OVP preset switch, the OVP voltage can be set by turning the potentiometer with a plain screwdriver. The set voltage is indicated on the voltmeter. The setting ranges of the OVP voltage are as follows:

PAL 16-40: 3 - 18 V

PAL 35-20: 3 - 38 V

⑯ Output terminal ("+" terminal)

Red binding post terminal. (Diameter of crimping terminal for connection: 8 mm)

⑰ GND terminal

⑱ Output terminal ("- " terminal)

White binding post terminal. (Diameter of crimping terminal for connection: 8 mm)

⑲ Service panel

To gain access to the service panel, remove the nameplate by removing its two M2 screws. The following adjustment and calibration controls are provided on the service panel. (For the adjusting and calibrating procedures, refer to Section 5 "MAINTENANCE.")

A.OS: Offset adjustment control for output current
V.OS: Offset adjustment control for output voltage
VMO: Voltage calibration control for preset OVP
VML: Voltage calibration control for voltage limit
switch
VMA: Full-scale calibration control for voltmeter
AMA: Full-scale calibration control for ammeter
AML: Current calibration control for current limit
switch

⑳ Rubber stud

㉑ Fan exhaust area

Air exit of the cooling package. As hot air comes out of this outlet, do not obstruct. The outlet must be positioned 30 cm or over from wall.

㉒ Input terminal block

Terminal block for input power terminals (M3)

㉓ Rear-panel output terminal block

Terminal block for "+" and "-" output terminals and remote sensing terminals, on the rear panel.

㉔ Terminal block

Terminal block for remote control terminals with voltage or resistance, output ON/OFF-control terminals, and one-control series/parallel operation terminals. (Refer to Section 4 "APPLICATIONS.")

㉕ Input power fuse holder

Fuse rating 120 VAC: 20 A
 240 VAC: 15 A

800504

②6 Serial No.

②7 Carrying handle

②8 Rubber stud

To serve as a shock absorber when carrying the instrument with its handle.

②9 DPO mounting hole

2-4. Operating Procedures

(A) Constant-voltage Operation

- (1) Turn off the OUTPUT switch.
- (2) Turn on the POWER switch. The POWER indicator lamp will turn on.
- (3) Keeping depressed the current/voltage limit switch, set the output voltage to the required value with the voltage setting knob. Also keeping depressed the current/voltage limit switch, set the output current limit value allowable to the load using the current setting knob.

(By the above procedure, the output voltage domain and output current domain of the instrument are set. When these settings have been done, no output voltage or current larger than the set values is fed to the load. For example, if the resistance of the load is large, the output voltage remains at the set voltage and the output current is suppressed within a correspondingly small value. If the load resistance is gradually reduced, the output current gradually increases. When the output current has reached the preset limit, however, the output current does not increase any longer and the output voltage starts falling instead. Even if the load resistance is reduced further and finally the output terminals are shorted, no output current larger than the preset limit flows. Thus, the operation modes are automatically switched between the constant-voltage mode and the constant-current mode to protect the load.)

- (4) Connect the load and turn on the OUTPUT switch.
- (5) The CV lamp (green) will turn on and the instrument will start operating in the constant-voltage mode.

- Notes:
- o When the load impedance is unpredictable or when the load is of such a nature that its resistance largely varies depending on the applied voltage and abrupt application of power is undesirable, set at first the output voltage at zero and then gradually increase the output voltage.
 - o The instrument produces no overshoots even when its input or output switch is turned on or off.
 - o Normally, the OVP voltage should be set at approximately 110% of the required output voltage. To set the OVP voltage, keeping depressed the OVP preset switch, adjust the OVP potentiometer so that the voltmeter indicates the required trip voltage. (For details, refer to Section 3-3.)
 - o If the output connection cables to the load are long, the constant-voltage characteristics at the load end may be degraded due to the inductance and resistance of the cables. To compensate for the inductance, connect an electrolytic capacitor of 1000 μ F to 10,000 μ F of good high-frequency characteristics to the load end with the minimum distance. To compensate for the resistance, use the remote sensing mode of operation as explained in Section 4-1.

(B) Constant-current Operation

- (1) Turn off the OUTPUT switch.
- (2) Turn on the POWER switch. The POWER indicator lamp will turn on.

- (3) Keeping depressed the current/voltage limit switch, set the output current to the required value with the current setting knob. Also keeping depressed the current/voltage limit switch, set the output voltage limit value allowable to the load using the voltage setting knob.
- (4) Connect the load and turn on the OUTPUT switch.
- (5) The CC lamp (red) will turn on and the instrument will start operating in the constant-current mode.

The instrument is of an automatic constant-voltage/constant-current switchover type. When the instrument is operating in the constant-current mode, if the load resistance increases, the output voltage increases as it is determined by $E_o = R_L \times I_o$, where E_o is output voltage, R_L is load resistance, and I_o is output current. When the output voltage has risen to the preset output voltage, the instrument operation is automatically switched over to the constant-voltage mode and the output current does not increase any longer, to protect the load.

- Notes:
- o When the load is of such nature that its impedance largely varies by self-heating, set a constant-voltage domain with a sufficient allowance within the allowable voltage range of the load.
 - o The instrument has a capacitor connected in parallel in the output circuit. When the load is of such nature that it causes the output voltage to change rapidly, the charge/discharge current is superimposed on the load current.

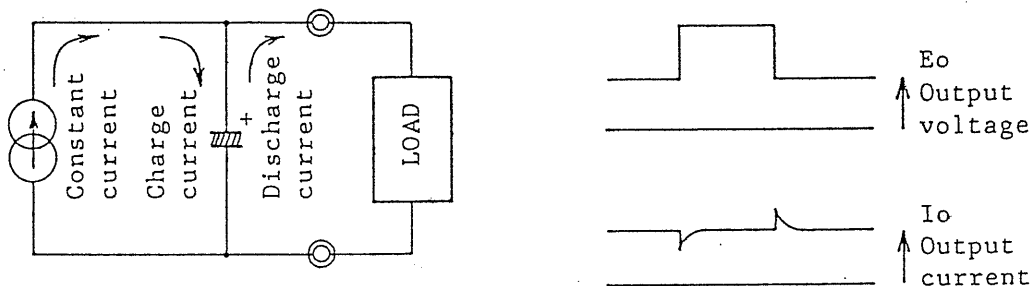

Figure 2-8

- o For on/off-control of the output when in the constant-current mode, control it by means of the terminal block on the rear panel (refer to Section 4-2.) If the output is directly on/off-controlled with a regular switch, an output current larger than the preset value may flow due to the charge/discharge current of the capacitor connected in the output circuit.

8020408

SECTION 3. PROTECTORS

3-1. Description

Regulated DC power supplies are used, as their name indicates, to supply regulated powers to loads of various types of electronic equipment. Demands for regulated DC power supplies have rapidly increased in recent years. As is the case for other types of electronic equipment, these instruments are required to include features of high accuracy, fast response, high reliability, high efficiency, high power factor, compactness, light weight, and economical prices. Various types of power supplies are available on the market today.

When selecting regulated DC power supplies, in addition to satisfying the required performances, special attention must be paid to some particular requirements which are substantially different from those required by other types of electronic equipment which handle electronic signals.

The above difference comes from the fact that regulated DC power supplies handle "powers." Malfunctioning or erroneous operation of the power supply leads to shut down of the overall system, damage to the power supply equipment or expensive load equipment, or to a fire in an extreme case. As the power supply provides the base for the entire electric and electronic circuits of the system to which it supplies the power, its reliability is very important. Protective features, which prevent serious damage when the power supply should fail, are important factors to be taken into consideration when selecting a power supply.

The PAL Regulated Power Supplies are incorporated with the various protective features as explained in this section.

3-2. Description of Protective Circuits

(1) Overvoltage protector (Preset OVP)

- o When the output voltage has exceeded the preset limit value, the power switch is shut off, the series control transistor is cut off and the switching regulator stops oscillating.

- o The operation pulse width is 50 msec.
- o To resume operation, turn off the POWER switch, wait in this state for about 5 seconds, and then turn on the POWER switch.
- o For such load as semiconductor which is not highly resistant against overvoltage and is apt to be damaged even with a slight overvoltage, use the thyristor-type high-speed OVP which is explained in the next item.

(2) High-speed overvoltage protector (crowbar protection circuit)

..... Option

- o When the output voltage has exceeded the preset limit voltage for 200 μ sec or over, the output circuit is shorted with a thyristor to suppress the output voltage, the power switch is shut off, the series control transistor is cut off, and the switching regulator stops oscillating.
- o As the output terminals are shorted, if the load is a battery or a large capacitor, a diode should be connected in series to the load.

(3) Voltage detector circuit

- o The voltage across the internal electrolytic filter capacitor is monitored and at the instant it has exceeded the preset value, the protective actions the same with those of the overvoltage protector take place. (See 3-2 (1)).

(4) Overcurrent protector

- o When the external signal which controls the output current of the power supply has exceeded the level for approximately 110% of the rated current of the power supply, the protective actions the same with those of the overvoltage protector take place. (See 3-2 (1)).

(5) Overheat Protector

- o Temperature of the heat sink of the semiconductor is monitored. When temperature of the heat sink has become higher than approximately 85°C (185°F), the protective actions the same with those of the overvoltage protector takes place. (See 3-2 (1)).

(6) Thermal fuse

- o The thermal fuse is provided in the winding of the subtransformer. It blows out to cut off the input power when temperature of the winding has become higher than approximately 135°C (275°F).

(7) Inrush current suppression circuit

- o To suppress the inrush current which flows when the input power is turned on.

(8) Input fuse

- o To break the input circuit when the input current has become abnormally large.

3-3. Operation Method of Overvoltage Protector (OVP)

o Setting Procedure

- o Press the OVP preset button so that the voltmeter indicates the OVP voltage (trip voltage). Adjust the OVP potentiometer so that the voltmeter indicates the required OVP voltage, using a plain screwdriver.

Note: Before starting operating the instrument for the actual load, raise the output voltage to confirm that the OVP action takes place at the preset OVP voltage.

- o The preset OVP voltage can be checked without causing any effect on the output even when the instrument is in operation. The protective functions remain effective even during the period the OVP preset button is kept depressed.

- o Selecting the OVP voltage

- o The OVP voltage (trip voltage) should be selected with respect to the voltage rating or the allowable maximum voltage of the load. If it is selected too close to the output voltage, unnecessary trips may be caused by transient spikes or noise superimposed on the output voltage.

The problem which occurs often with power supplies incorporated with an overvoltage protection function is "how to cope with noise which causes no trouble to the load but which causes unnecessary trips of the overvoltage protection circuit." For the PAL Power Supplies, the OVP protector is designed so that it responds to a pulse of 50 msec or over.

- o In general, the OVP voltage should be set at approximately 110% of the output voltage.

Note: When the OVP protector has detected an overvoltage, it shuts down the power switch, cuts off the power transistor and stops oscillation of the switching regulator. However, it does not have any function of actively reducing the overvoltage which has appeared in the output circuit. Therefore, for such types of loads that even only several volts of overvoltage with approximately 100 msec of periods are not tolerable, the thyristor-type high-speed OVP protector function is needed.

SECTION 4. APPLICATIONS

4-1. Remote Sensing

Voltage drop caused by the load connection wire resistance and contact resistance can be compensated for.

- (1) Turn off the input power switch.
- (2) Disconnect the jumper wires from between \oplus S and \oplus terminals and between \ominus S and \ominus terminals on the instrument rear panel.
- (3) Connect the \oplus S and \ominus S wires to the point where the output voltage drop is required to be compensated for. (Use a shielded cable in order to prevent inducing of ripple voltage. Connect the external shielding wire to the \ominus line of the output.)
- (4) Connect to the sensing point (the point where the \oplus S and \ominus S wires are connected) an electrolytic capacitor (C1) of several hundreds to several thousands microfarads and of good high-frequency characteristics, with the minimum connecting distance.

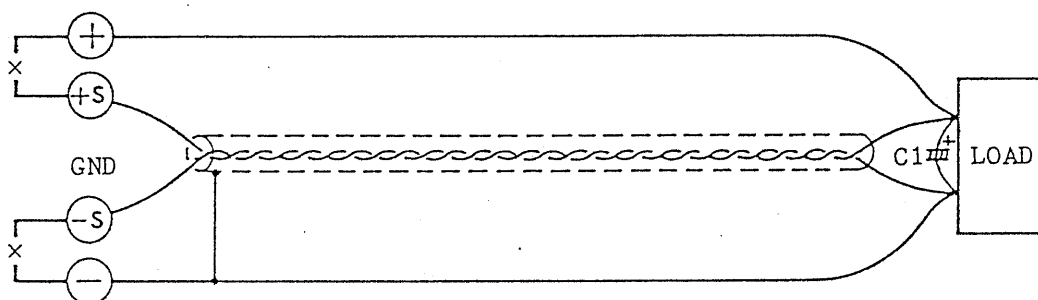

Figure 4-1

- Notes: 1. By this remote sensing feature, up to approximately 1.2 V of voltage drop per one-way of connection wire can be compensated for. Note that, if the voltage drop is larger than 300 mV, the maximum rated voltage is reduced by the corresponding amount. (For example, if 1-volt compensation per one-way is made, the maximum rated voltage becomes $35 - 2 = 33$ V. Do not use it for voltage higher than 33 V.)

833603

2. If the load connection cable wires are long, phase shift caused by inductance and capacitance of the cable wires becomes substantial and the circuit may oscillate. Be sure to connect an electrolytic capacitor (C1) to the load.
3. If the load is of such nature that it draws the current periodically, the stability of the output voltage at the load end may be badly degraded due to the above capacitor (C1) and due to the inductance (L) of the load connection cable wires which causes a voltage drop of $[L\frac{di}{dt}]$. To minimize the voltage stability, use cable wires of a large wire gauge, make the wiring distance as short as possible, and strand the wires to reduce inductance.

4-2. ON/OFF-control of Output

The output can be remote-controlled for ON/OFF operation with an external contact signal, for either one of the following two types of turning off:

- 4-2-1. To turn off the output voltage accurately to zero volts
- 4-2-2. To turn off the output voltage to a certain voltage preset by the voltage limit switch

4-2-1. To Turn Off the Output Voltage Accurately to Zero Volts

- (1) Turn off the input POWER switch.
- (2) Connect a remote control contact (switch S1) between terminals ③ and ④ of the terminal block on the rear panel. Turn on the OUTPUT switch on the front panel.
- (3) Turn on the input POWER switch and close the remote control contact.

859607

- (4) Adjust the output voltage to zero volts with the Vos potentiometer on the service panel.

Table 4-1

Contact (S1)	Open	Closed
Output	ON	OFF

Contact ratings:

10 VDC, 100 mA

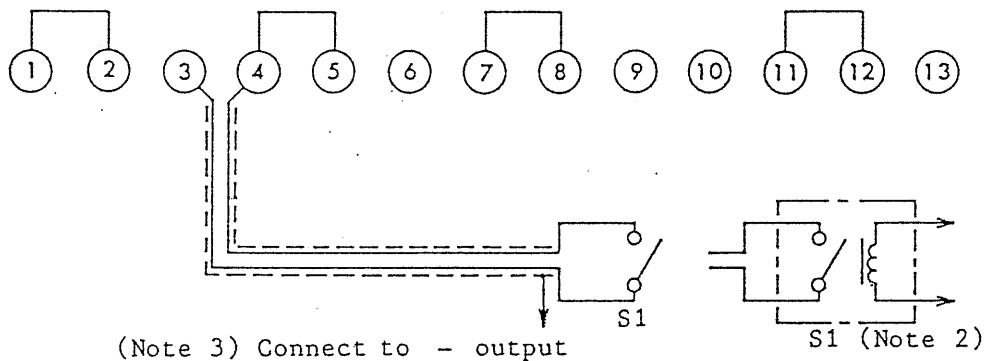

Figure 4-2

- Notes:
1. When the output is off, the voltage limit switch of the front panel remains idle.
 2. The circuit between terminals ③ and ④ is the input circuit of the error amplifier. Therefore, in order to prevent erroneous trips caused by noise, use a small DC relay and extend the relay coil wires when the instrument is used in an environment with noise or the remote control distance is long.
 3. Use a shielded cable for connection from the terminals to the external contact (S1). Connect the shielding wire to the (-) output terminal.
 4. When the remote programming operation (control of the output with calibrated external voltage or resistance) is used in parallel, Vos is used by the remote programming operation and is not available for this purpose. In such case, connect a potentiometer of approximately

833605

100 ohms in series to the contact (S1) and adjust the potentiometer so that the output voltage becomes zero volts when the contact is closed.

5. The relationships between the contact (S1) and the OUTPUT switch on the front panel is such that the OFF state has the priority.

4-2-2. To Turn Off the Output Voltage To a Certain Voltage Preset By the Voltage Limit Switch

- (1) Turn off the input POWER switch.
- (2) Connect a remote control contact (switch S2) between terminals (6) and (7) of the terminal block on the rear panel.

Table 4-2

Contact (S2)	Open	Closed
Output	ON	OFF

Contact ratings: 10 VDC,
100 mA

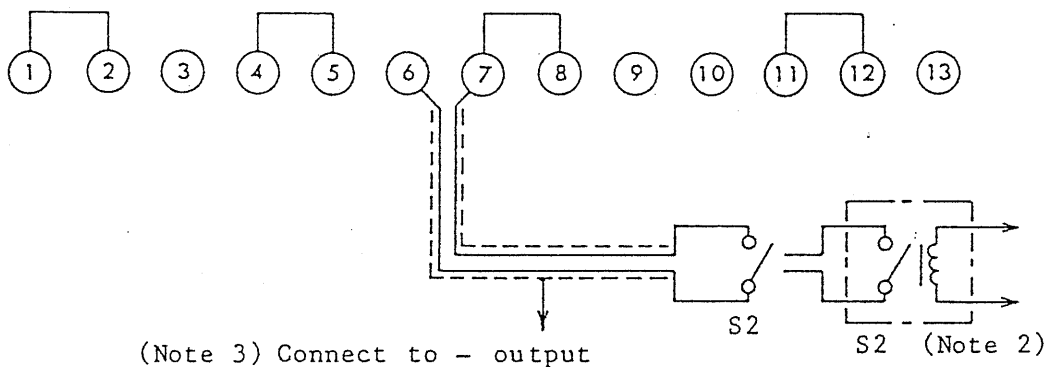

Figure 4-3

- Notes:
1. When the output is off, the current limit switch of the front panel remains idle.
 2. The circuit between terminal (6) and (7) is the input circuit of the error amplifier. Therefore, in order to prevent erroneous trips caused by noise, use a small relay and extend the relay coil wires when the instrument

833606

is used in an environment with noise or the remote control distance is long.

3. Use a shielded cable for connection from the terminals to the external contact (S2). Connect the shielding wire to the (−) output terminal.
4. The relationships between the contact (S2) and the OUTPUT switch on the front panel is such that the OFF state has the priority.
5. When the output is off, the output voltage is approximately -100 mV.

4-3. Remote Control of Output Voltage

When in the constant-voltage mode of operation, the output voltage can be controlled in the following types of remote control operation.

- 4-3-1. Control of output voltage with an external voltage
- 4-3-2. Control of output voltage with an external current
- 4-3-3. Linear control of output voltage with an external resistance
- 4-3-4. Fail-safe-type control of output voltage with external resistance

4-3-1. Control of Output Voltage With an External Voltage

- o The output voltage can be controlled with a voltage signal of 0 to +10 V with reference to (−S).
- (1) Turn off the input POWER switch.
 - (2) Disconnect the jumper from between terminals (1) and (2) of the rear terminal block.
 - (3) Apply an external control input voltage (E1) to between terminals (−S) and (1), with the positive line to terminal (1).

00000000

- (4) Remove the knob of the voltage setting potentiometer and install the guard cap, to semi-fix the potentiometer.
- (5) Turn on the input POWER switch. (Turn on the OUTPUT switch.)
- (6) Adjust the offset (zero volts) with the Vos control of the service panel and adjust the full-scale voltage with the voltage setting potentiometer.

* Be sure to check the electrical connections and settings of controls before turning on the power, lest damage should be caused to the instrument and load.

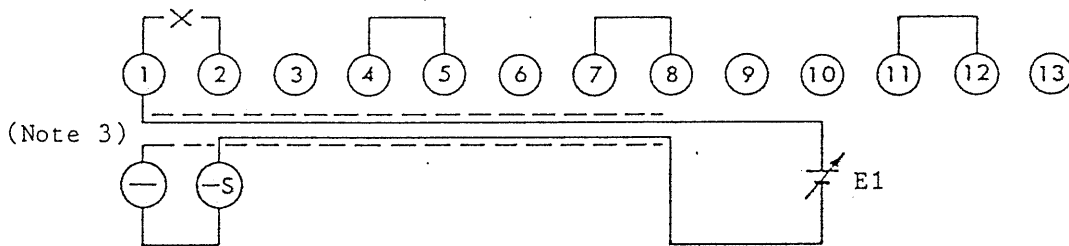

Figure 4-4

- o The relationships between the output voltage (E_o) and the input voltage (E_1) can be expressed as follows:

$$E_o = \frac{1}{9} \cdot E_{max} \cdot E_1 \cdot \alpha \text{ [V]}$$

$$0 \leq \alpha \leq 1 \text{ [1/V]}$$

$$0 \leq E_1 \leq 10 \text{ [V]}$$

E_{max} : Maximum rated voltage [V]

- o Term α is a factor (0 to 1) which depends on the voltage setting potentiometer. When the potentiometer is at the counterclockwise extreme position, α is 0; when it is at the clockwise extreme position, α is 1. Note that, therefore, if an input voltage (E_1) of 10 V is applied with the potentiometer set at the clockwise extreme position, the output voltage will become 110% of the rated voltage.

Notes: 1. Make sure that the output voltage is within the rated voltage.

000000

2. The resistance between terminals $\ominus S$ and $\textcircled{1}$ is approximately 9 k Ω .
3. The noise component of the input voltage (E1) is amplified and conveyed to the output circuit. Use a voltage signal which contains less noise component. For the input voltage signal connection, use a shielded cable (or a stranded pair of wires) and connect the shielding wire to the \ominus output. When wiring a long distance, pay full attention to noise.
4. Offset control potentiometer: So adjust that the output voltage becomes zero volts when the input is zero volts.
Full-scale control potentiometer: This potentiometer is used to set the ratio of the output voltage with respect to the input voltage. Normally, this potentiometer is set for the maximum voltage.

4-3-2. Control of Output Voltage With an External Current

- o The output voltage can be controlled with a current signal of 0 to +1 mA with reference to $\ominus S$.
 - (1) Turn off the input POWER switch.
 - (2) Disconnect the jumper from between terminals $\textcircled{1}$ and $\textcircled{2}$ of the rear terminal block.
 - (3) Apply an external control input current (I_1) to between terminals $\ominus S$ and $\textcircled{4}$, with the positive line to terminal $\textcircled{4}$.
 - (4) Remove the knob of the voltage setting potentiometer and install the guard cap, to semi-fix the potentiometer.
 - (5) Connect between terminals $\textcircled{3}$ and $\textcircled{4}$ a protective Zener diode (D1) ($V_2 = 12 \text{ V}$, 250 mV).
 - (6) Turn on the input POWER switch. (Turn on the OUTPUT switch.)

833610

(7) Adjust the offset (zero volts) with the Vos control of the service panel and adjust the full-scale voltage with the voltage setting potentiometer. (See Note 4 of Section 4-3-1.)

* Be sure to check that the electrical connections are correct before turning on the power, lest the instrument should be damaged by wrong connections.

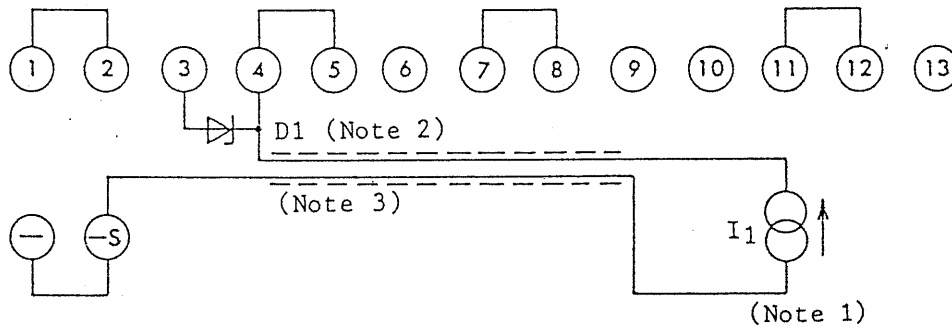

Figure 4-5

o The relationships between the output voltage (E_o) and the input current (I_1) can be expressed as follows:

$$E_o = E_{max} \cdot I_1 \cdot \alpha \text{ [V]}$$

$$0 \leq \alpha \leq 1 \text{ [1/mA]}$$

$$0 \leq I_1 \leq 1 \text{ [mA]}$$

E_{max} : Maximum rated voltage [V]

o Term α is a factor (0 to 1) which depends on the voltage setting potentiometer. When the potentiometer is set at the counterclockwise extreme position, α is 0; when it is at the clockwise extreme position, α is 1.

Notes: 1. o Make sure that the output voltage is within the rated voltage.

o The open voltage of the input current source should be approximately 1 V.

833610

- o Note that the ripple component of the input current is conveyed to the output circuit.
- o Impedance of terminal (4) is 0 Ω .
- 2. o For the zener diode (D1), use one which has less leak current. Leak current will cause degradation of linearity of E_o-I_1 characteristics.
- 3. o Use a shielded cable or a stranded pair of wires. Connect the shielding wire to the (-) terminal, if required.
- o Note that, if the instrument is operated in an environment with noise, the operation may become unstable and erroneous operations may result due to noise superimposed on the input current signal.

4-3-3. Linear Control of Output Voltage With an External Resistance

- (1) Turn off the input POWER switch.
- (2) Disconnect the jumper from between terminals (4) and (5).
- (3) Connect a potentiometer (variable resistor) (R1) between terminals (3) and (4).
- (4) Remove the knob of the voltage setting potentiometer and install the guard cap, to semi-fix the potentiometer.
- (5) Turn on the input POWER switch. (Turn on the OUPUT switch.)
- (6) Adjust the offset (zero volts) with the Vos control of the service panel. (See Note 4 of Section 4-3-1.)

* Before turning on the power, check once more that the electrical connections has been correctly done as wrong connections may cause damage to the instrument. (Note that the output voltage becomes the uncontrolled state if the R1 circuit becomes open.)

84 3 21 233611 A

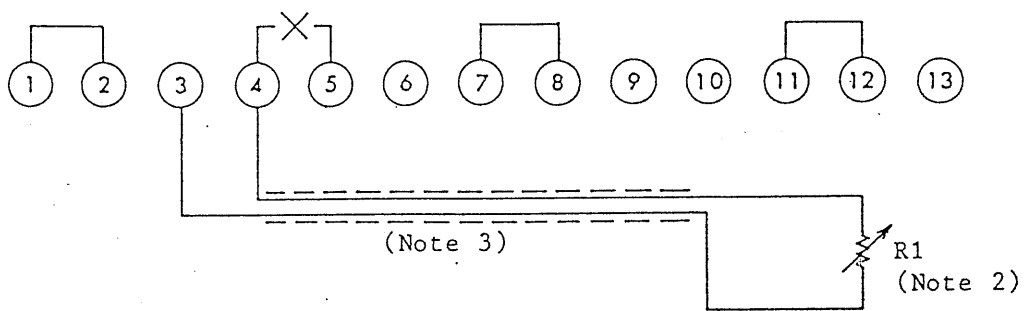

Figure 4-6

- o The relationships between the output voltage (E_o) and the input resistance (R_1) can be expressed as follows:

$$E_o = \frac{1}{10} \cdot R_1 \cdot E_{max} \text{ [V]}$$

$$0 \leq R_1 \leq 10 \text{ [k}\Omega\text{]}$$

E_{max} : Maximum rated voltage [V]

- Notes:
1. Potentiometer R_1 is inserted in the feedback loop of the operational amplifier. If the potentiometer circuit is made open, an overvoltage may be caused in the output voltage circuit. When using such device as a switch to change the output voltage, use a short-circuit-type of device so that the circuit is not made open. In the case that this feature is undesirable from the viewpoint of degradation of reliability or safety, use the method explained in Section 4-3-4.
 2. A constant current (1 mA) flows in the potentiometer (R_1). In order to prevent drift which could be caused by overheating of the potentiometer itself, use a potentiometer of 1/2-watt or more of power rating, and of good temperature coefficient, aging, and noise characteristics, such as a metal film potentiometer.
 3. For connections to the potentiometer (R_1), use a shielded cable (or a pair of stranded wires) and connect the shielding wire to the \ominus output. When the wiring distance is long, pay full attention against induction noise and ripples.

832612

4. Pay attention to the resistance of the cable wires, since the resistance will cause an offset voltage.

5. Pay attention so that the output voltage does not exceed the rated voltage.

4-3-4. Fail-safe-type Control of Output Voltage With an External Resistance

This mode of operation is used to safeguard against overshoots to the output voltage when the control circuit (resistance circuit) is made open. When in this mode, if the resistance circuit is made open, the output voltage is reduced. Therefore, a regular switch or a relay can be used to change the resistance without causing overshoots of output voltage.

On the other hand, this mode of operation has a disadvantage that the relationships between the control resistance and the output voltage is not linear. Especially at the low power, the resistance becomes impracticably large.

- (1) Turn off the input POWER switch.
- (2) Disconnect the jumper from between terminals ① and ② of the rear terminal block.
- (3) Connect a potentiometer (variable resistor) (R2) between terminals ① and ②.
- (4) Remove the cap of the voltage setting potentiometer and install the guard cap, to make the potentiometer semi-fixed.

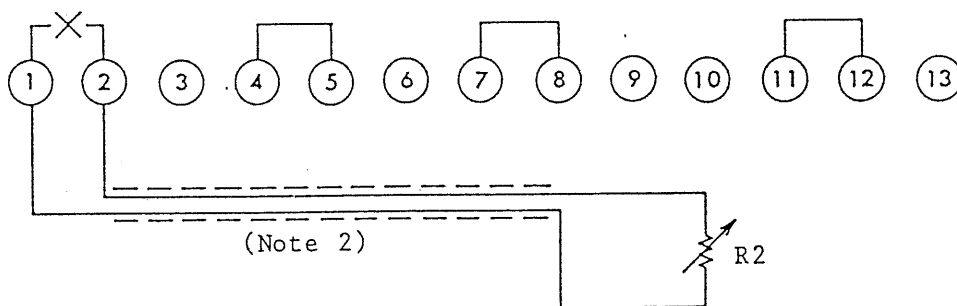

Figure 4-7

830613

- o The output voltage (E_o) and input resistance (R_2) are inversely proportional as given by the following formula:

$$E_o = \frac{9}{R_2 + 9} \cdot E_{max} \cdot \alpha \text{ [V]}$$

$$0 \leq R_2 \leq \infty \text{ [k}\Omega\text{]}$$

$$0 \leq \alpha \leq 1$$

E_{max} : Maximum rated voltage [V]

α : Factor which depends on voltage setting potentiometer.

The clockwise extreme position is for 1 and the counterclockwise extreme position is for 0.

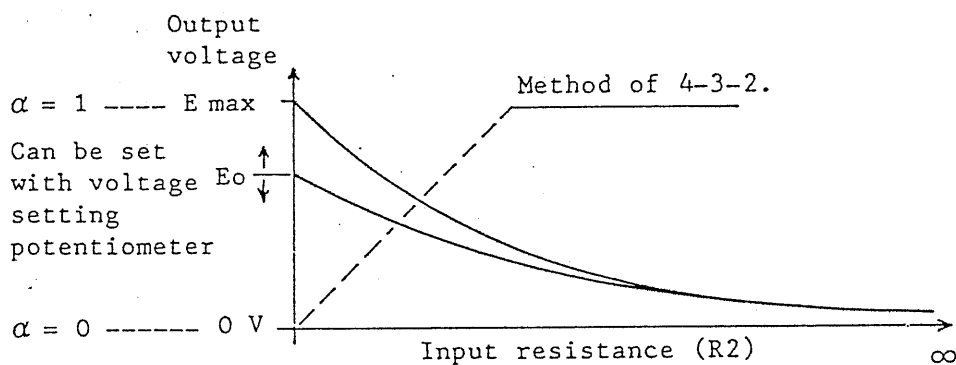

Figure 4-8

- Notes:
- o The maximum voltage applied to potentiometer R_2 is approximately 10 V and the maximum current is 1 mA.
 - o Use a potentiometer which has good temperature coefficient, aging, and noise characteristics.
 - o Note that, when the resistance of R_2 is approximately 100 k Ω or over, the output characteristics may be degraded due to induction noise.
 - o For electrical connections to the potentiometer (R_2), use a shielded cable and connect the shielding wire to the \ominus output. When the wiring distance is long, pay attention to induction noise.

803614

4-4. Remote Control of Output Current

When in the constant-current mode of operation, the output current can be controlled in the following types of remote control operation.

- 4-4-1. Control of output current with an external voltage
- 4-4-2. Control of output current with an external current
- 4-4-3. Linear control of output current with an external resistance
- 4-4-4. Fail-safe-type control of output current with an external resistance

4-4-1. Control of Output Current With an External Voltage

o The output current can be controlled with an external voltage signal of 0 to +10 V with reference to \ominus output (*). (*: To put it more accurately, with reference to terminal $\textcircled{10}$ of the rear terminal block.)

- (1) Turn off the input POWER switch.
- (2) Disconnect the jumper from between terminals $\textcircled{11}$ and $\textcircled{12}$ of the rear terminal block.
- (3) Apply an external control voltage (E2) between terminals $\textcircled{10}$ and $\textcircled{11}$, with the positive line to terminal $\textcircled{11}$.
- (4) Remove the knob of the current setting potentiometer and install the guard cap, to make the potentiometer semi-fixed.
- (5) Connect an ammeter (shunt resistor) in the output circuit.
- (6) Turn on the input POWER switch. (Turn on the OUTPUT switch.)
- (7) Adjust the offset (zero amperes) with the AOS control of the service panel and adjust the full-scale current with the current setting potentiometer.

* Before turning on the POWER switch, check that the electrical connections and settings of controls have been correctly done, lest damage should be caused to the instrument or the load.

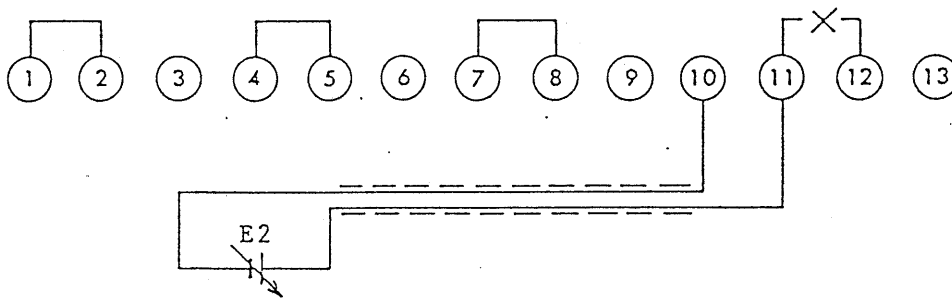

Figure 4-9

- o The relationships between the output current (I_o) and the input control voltage (E_2) can be expressed as follows:

$$I_o = \frac{1}{9} \cdot I_{max} \cdot E_2 \cdot \beta \text{ [A]}$$

$$0 \leq \beta \leq 1 \text{ [1/V]}$$

$$0 \leq E_2 \leq 10 \text{ [V]}$$

I_{max} : Maximum rated current [A]

- o Term β is a factor (0 to 1) which depends on the current setting potentiometer. The counterclockwise extreme position of the potentiometer is for $\beta = 0$ and the clockwise extreme position is for $\beta = 1$. Note, therefore, that, if the potentiometer is turned to the clockwise extreme position and a control voltage (E_2) of 10 V is applied, the output current becomes 110% of the rated current.

Notes: 1. Pay attention so that the output current does not exceed the rated current.

2. The input resistance between terminals $\textcircled{-S}$ and $\textcircled{11}$ is 20 k Ω to 30 k Ω .

3. The noise component of the input signal voltage (E_2) is amplified and appears in the output circuit. Use a control signal voltage which contains less ripple noise component.

4. For input signal connection, use a shielded cable (or a pair of stranded wires). Connect the shielding wire to

822616

the \ominus output. When the wiring distance is long, pay full attention to external induction noise.

5. Offset control potentiometer: To adjust the output current at zero amperes when the input control voltage is zero volts.

Full-scale control potentiometer: To adjust the ratio between the input control voltage and the output current. It should be adjusted to the maximum current.

4-4-2. Control of Output Current With an External Current

- o The output current can be controlled with an external control current of 0 to several milliamperes, with reference to the \ominus output. (Since this control operation employs a current for control, the reference point \ominus can be used in common with the case of the output voltage control. Thus, both output voltage and current can be controlled with the same common-line system.)
 - (1) Turn off the input POWER switch.
 - (2) Disconnect the jumper from between terminals $\textcircled{11}$ and $\textcircled{12}$ of the rear terminal block.
 - (3) Apply the control input current (I_2) between terminals $\textcircled{10}$ and $\textcircled{7}$, with terminal $\textcircled{7}$ for the positive line.
 - (4) Remove the knob of the current setting potentiometer and install the guard cap, to make the potentiometer semi-fixed.
 - (5) Connect a protecting zener diode (D2) ($V_z = 12 \text{ V}$, 250 mW) to between terminals $\textcircled{6}$ and $\textcircled{7}$.
 - (6) Connect an ammeter (shunt resistor) in the output circuit.
 - (7) Turn on the input POWER switch. (Turn on the OUTPUT switch.)
 - (8) Adjust the offset (zero amperes) with the AOS control of the service panel and adjust the full-scale current with the current setting potentiometer. (See Note 5 of Section 4-4-1.)

833617

* Terminal (7) is of the input circuit of the operational amplifier. Pay attention so that the instrument is not damaged by wrong wiring or excessive input voltage. Check these items once more before turning on the POWER switch.

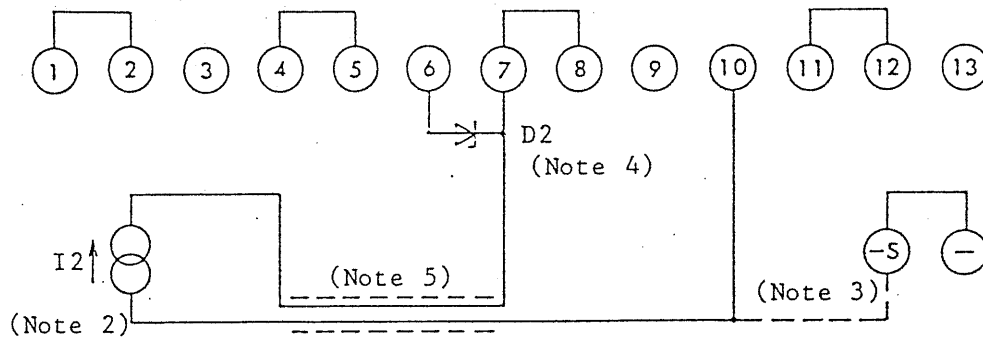

Figure 4-10

o The relationships between the output current (I_o) and the input current (I_2) can be expressed as follows:

$$I_o = \frac{1}{A_1} \cdot I_{max} \cdot I_2 \cdot \beta \quad [A]$$

$$0 \leq \beta \leq 1 \quad [1/mA]$$

$$0 \leq I_2 \leq A_1 \quad [mA]$$

I_{max} : Maximum rated current [A]

The values of A_1 are as shown in Table 4-3.

Table 4-3

Model	16-40	35-20		
A_1	0.4	0.7		

o Term β is a factor (0 to 1) which depends on the current setting potentiometer. The counterclockwise extreme position of the potentiometer is for $\beta = 0$ and the clockwise extreme position is for $\beta = 1$.

Notes: 1. o Pay attention so that the output current does not exceed the rated current.

2. o The impedance of terminal (7) is zero ohms.

0003518

- o Note that the ripple component of the input signal current is conveyed to the output circuit as an output ripple current.
3. o The common line of the input signal current can be changed from terminal ⑩ to terminal $\ominus S$ (the reference point when in the output voltage control mode of operation). In this case, a compliance voltage (follow-up range) of approximately -2 V is needed for the input current signal source. (Since the potential of terminal ⑩ varies for a range of approximately 0 to -2 V when in the remote-sensing mode of operation, a current signal source which can provide a current signal without being affected by this range of voltage variation is needed.)
 4. o For the zener diode (D2), use a one the leak current of which is small. Note that the leak current causes degradation of linearity between the output current (I_o) and the control input current (I_2).
 5. o For signal connection, use a shielded cable (or a pair of stranded wires). Connect the shielding wire to the \ominus output, as required.
 - o Note that, if the instrument is operated in an environment with large noise, the operation may become unstable and erroneous operation may result due to spikes and other noise induced in the input signal line.

4-4-3. Linear Control of Output Current With an External Resistance

- o This mode of operation is ideal for programmed remote control operation as the output (current) is directly proportional to the input (resistance).

(1) Turn off the input POWER switch.

0000000000

- (2) Disconnect the jumper from between terminals ⑦ and ⑧ of the rear terminal block.
- (3) Connect a potentiometer (variable resistor) (R3) between terminals ⑥ and ⑦.
- (4) Remove the knob of the current setting potentiometer and install the guard cap, to make the potentiometer a semi-fixed type.
- (5) Connect an ammeter (shunt resistor) in the output circuit.
- (6) Turn on the input POWER switch. (Turn on the OUTPUT switch.)
- (7) Adjust the offset (zero amperes) with the AOS control of the service panel. (See Note 5 of Section 4-4-1.)

* Make it double sure that the electrical connections have been correctly done. If the R3 circuit is made open, the output falls into an uncontrolled state. Check them once more before turning on the power.

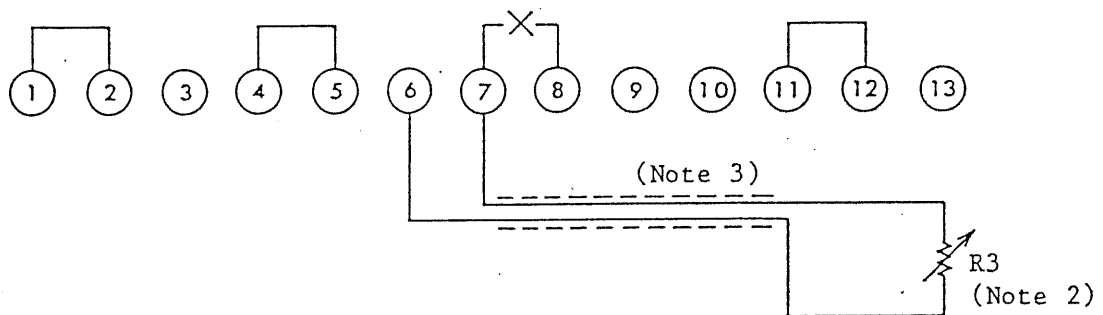

Figure 4-11

- o The relationships between the output current (I_o) and the input signal resistance (R_3) can be expressed as follows:

$$I_o = I_{max} \cdot R_3 \text{ [A]}$$

$$0 \leq R_3 \leq 1 \text{ [k}\Omega\text{]}$$

I_{max} : Maximum rated current [A]

84.3.21 8336204

- Notes:
1. o Since potentiometer R3 is connected in the feedback loop of the operational amplifier, an overcurrent will be caused if the R3 circuit is made open. Therefore, in such case that the output current is changed by selecting resistors using a selector switch, use a short-type of switch so that the circuit is not made open at any instant. When this feature is undesirable, use the method explained in Section 4-4-4.
 2. o The maximum voltage applied to R3 is 10 V and the maximum current is 0.5 mA. Use a resistor (a metal film type, for example) of 1/4-watt or over, and of good temperature coefficient, aging and noise characteristics.
 3. o For wiring to R3, use a shielded cable (or a pair of stranded wires) and connect the shielding wire to the \ominus output.
 - o Note that the resistance of the wiring wires will cause an offset current.
 - o When the wiring distance is long, pay attention to induction noise and ripples, especially when the environment is with full of noise.
 4. o Pay attention so that the output current does not exceed the rated current.

4-4-4. Fail-safe-type Control of Output Current With an External Resistance

- o This mode of operation has an advantage that, when the control resistance circuit is made open, the output current is reduced for a fail-safe feature. Therefore, a regular switch or a relay can be used to select resistors for output current control, without causing overshoots of the output current.

823024

On the other hand, this mode of operation has a disadvantage that the output current is not linearly proportional to the control input resistance. Especially when the controlled output current is small, an impracticably large resistance is needed.

- (1) Turn off the input POWER switch.
- (2) Disconnect the jumper from between terminals (11) and (12).
- (3) Connect a potentiometer (variable resistor) (R4) between terminals (11) and (12).
- (4) Remove the knob of the current setting potentiometer and install the guard cap, making the potentiometer a semi-fixed type.

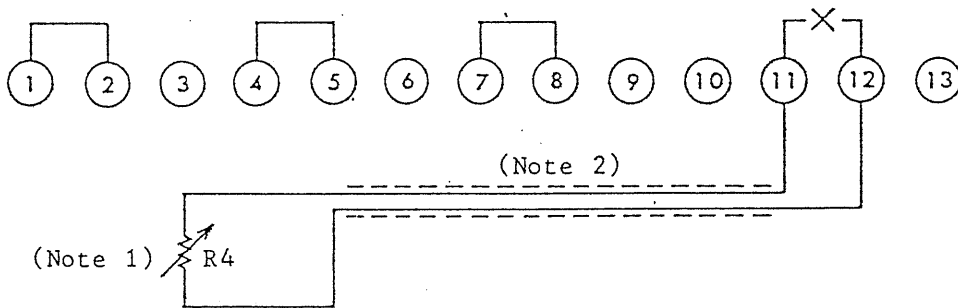

Figure 4-12

- o The output current (I_o) is inversely proportional to the control input resistance (R_4) as expressed with the following formula:

$$I_o = \frac{A_2}{R_4 + A_2} \cdot I_{max} \cdot \beta \text{ [A]}$$

$$0 \leq \beta \leq 1$$

$$0 \leq R_4 \leq \infty \text{ [k}\Omega\text{]}$$

I_{max} : Maximum rated current

- o Term β is a factor (0 to 1) which depends on the current setting potentiometer. The counterclockwise extreme position of the potentiometer is for $\beta = 0$ and the clockwise extreme position is for $\beta = 1$.

838622

- o The value of A2 differs by the model as shown in Table 4-4.

Table 4-4

Model	16-40	35-20		
A2 [kΩ]	22.75	13.0		

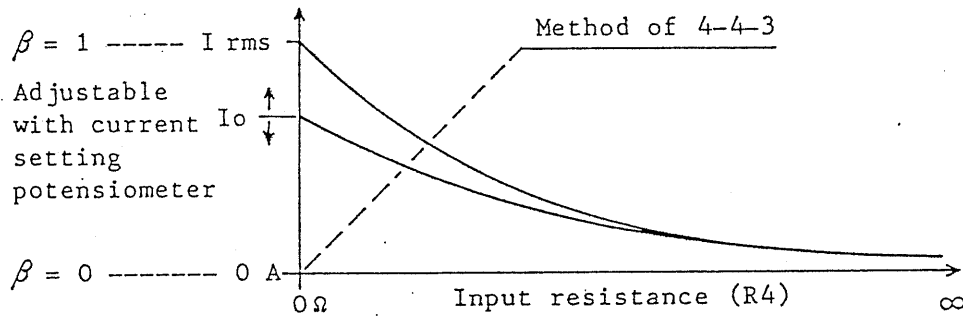

Figure 4-13

- Notes:
- o The maximum voltage applied to resistor R4 is 10 V and the current is 1 mA.
 - o Use a potentiometer (variable resistor) of good temperature coefficient, aging and noise characteristics.
 - o Note that the output characteristics may be degraded due to induction noise when the resistance of R4 is approximately 100 kΩ or over.
 - o For wiring to R4, use a shielded cable and connect the shielding wire to the \ominus output.
 - o When the wiring distance is long, pay full attention to induction noise and other disturbances.

000000

4-5. Series Operation and Parallel Operation

4-5-1. Series Operation

- o Two or more PAL Power Supplies can be operated being connected in series to obtain a higher voltage.

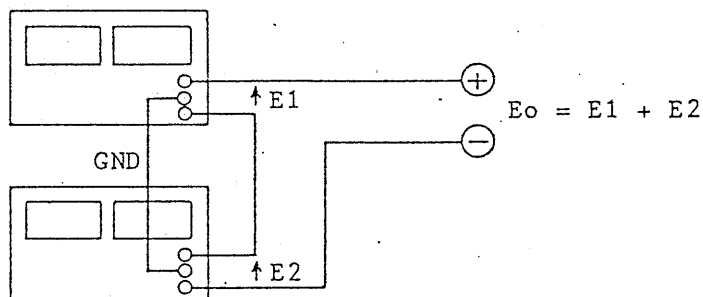

Figure 4-14

- Notes:
1. The number of units which can be connected in series is limited by the withstanding voltage (250 V) of the units with respect to the ground. (For example, when the units are operated with 35 V, up to 7 units can be operated being connected in series as $250 \div 35 = 7$ (remainder 5)).
 2. To make equal the chassis potentials of all units, connect the GND terminals of all units to a common potential.
 3. Make sure that the POWER switches of all units are turned on when in series operation.

4-5-2. Parallel Operation

- o Two or more PAL Power Supplies can be operated being connected in parallel to obtain a larger current capacity.

853024

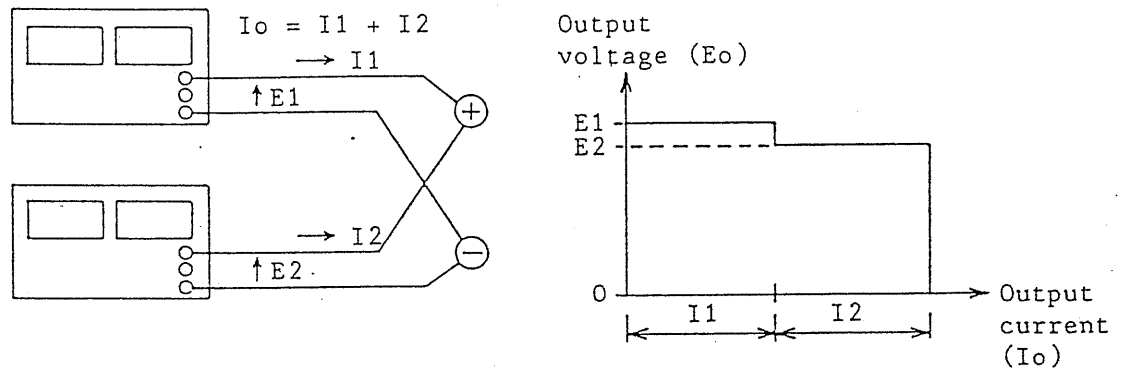

Figure 4-15

Notes: 1. Pay attention so that no higher voltage than the rated voltage is applied to the output circuit.

2. When operating the units in the constant-voltage mode, make their output voltages uniform. The operation in this case is as follows: At first, the current is fed from the unit of the highest output voltage and, when this unit has entered the constant-current domain and its output voltage has fallen, the next unit starts feeding the current. Thus, one of the units operates in the constant-voltage mode, always. The differences of the output voltages of the units are reflected as output voltage variation for the load.

(When the units are operated in the constant-current mode, the constant-current mode indicator lamps of all units are on.)

89-36-25

4-6. One-control Parallel Operation

One master unit and any number of slave units can be operated in parallel to increase the current capacity, controlled by one unit (master unit) for operation.

Note: The units of the same model alone can be used in this mode.

- (1) Turn off the input POWER switch.
- (2) Disconnect the jumpers from between terminals (11) and (12) of the rear terminal blocks of the slave units, and connect a jumper between terminals (10) and (11) of the rear terminal block of each of the slave unit.
- (3) Connect terminal (9) of the master unit to terminals (6) of the slave units.
- (4) Connect the output terminals of all units to the load, using wires of the same gauge and same length.

Note: Note that, of the PAL Series Power Supplies, unless the gauges and lengths of the (-) output wires are uniform (to put it more accurately, unless the potential differences between the (-) output terminals and the (-) terminal of the load) current distributions among the units will become ununiform.

- (5) Turn the voltage setting potentiometers of the slave units to the clockwise extreme position.
- (6) When remote sensing and/or remote control are needed, remote control the master unit.

- Notes:
1. o To indicate the output operation mode, the CV or CC indicator lamp of the master unit turns on.
o Of the slave units, the CC lamps are constantly on.
 2. o For the wires for connection to the load, see Table 2-1 of Section 2.

033628

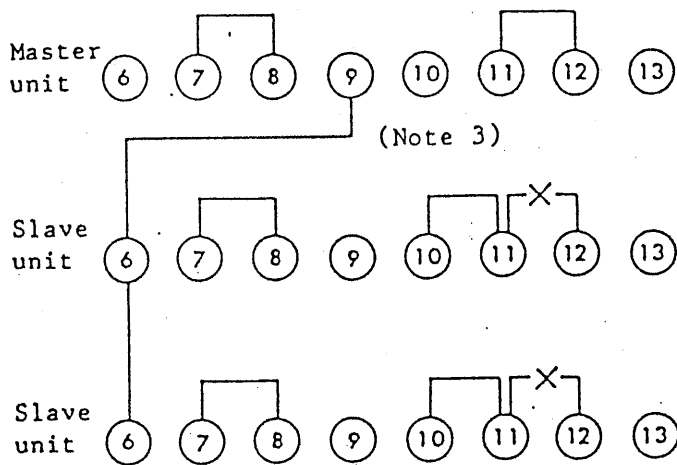
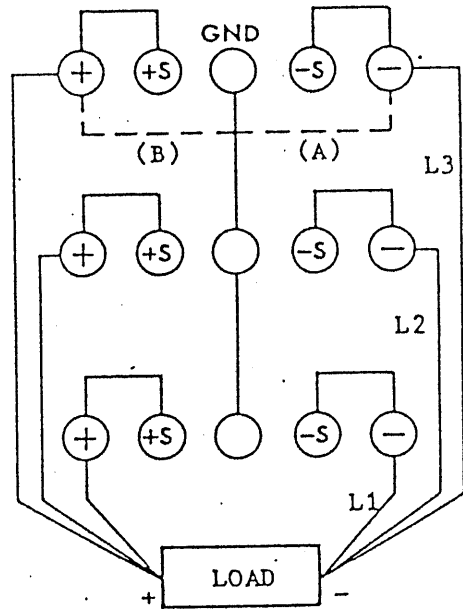

Figure 4-16



L1 = L2 = L3

(A): Positive ground

(B): Negative ground

3. o Connect the GND to the (+) or (-) line, unless there is any due reason they should not be connected.
4. o If OVP function is needed, OVP setting should be made for all of the master and slave units.

4-7. One-control Series Operation

- o One master unit and one or more slave units can be operated in series to obtain a higher output voltage (up to 250 V), controlled by one unit (master unit) for operation.

- (1) Turn off the input POWER switches of the units.
- (2) Referring to Figure 4-17, the unit at the bottom is the master unit and the other units are slave units.

Disconnect the jumpers from between terminals (1) and (2) and between terminals (4) and (5) of the rear terminal block of each of the slave units, and connect a jumper between terminals (4) and (-S).

100.4.27

833627B

- (3) Connect a resistor R5 (R6) between terminal ③ of the slave unit and terminal ⑤ of the unit below it as shown in Figure 4-17.
- (4) Connect in series the output terminals of all units.
- (5) Connect in common the GND terminals of all units to the required potential.
- (6) Turn the current setting potentiometers of all slave units to the clockwise extreme position.

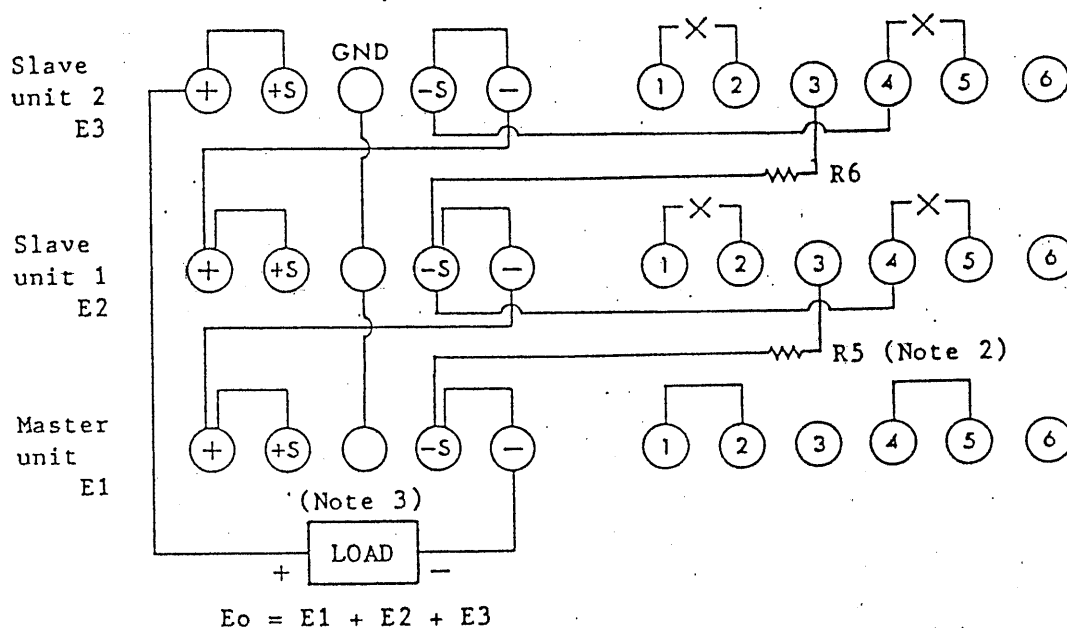

Figure 4-17

- o To select the resistance of the external resistor R5 (R6), use the following formula:

$$R_5 = \left(\frac{E_1}{E_2} \times A \right) - B \text{ [k}\Omega\text{]}$$

$$R_5 \text{ [k}\Omega\text{]} \geq 0, \quad (E_2 \leq \frac{A}{B} \cdot E_1)$$

E1: Output voltage of master unit [V]

E2: Output voltage of slave unit 1 [V]

E3: Output voltage of slave unit 2 [V]

190.4.27

833628B

- o For the external resistor R5 [kΩ], use a resistor of good temperature coefficient, aging and noise characteristics, with a wattage of 1/2-watt or over. For the values of A and B, see Table 4-5.

Table 4-5

Model	16-40	35-20		
A [kΩ]	9	18		
B [kΩ]	5	5		

- o To select the resistance for R6 using the above formula, use E2 for E1, E3 for E2, and R6 for R5.

- Notes:
- o The number of units which can be connected in series depends on the withstanding voltage of the units with respect to the ground. (For example, if the units are operated with output voltage 35 V, the maximum number of units which can be connected in series is calculated to be seven as $250 \div 35 = 7$ (remainder 5).
 - o Install resistor R5 (R6) as close to terminal (3) as possible. The reference voltage is applied between terminals (3) and (-S). To prevent ripples of the output caused by induction, use a shielded cable as required.
 - o To keep the chassis potentials of all units uniform, be sure to connect together the GND terminals of all units to a certain same potential required.
 - o When operating in the series mode, be sure to turn on the POWER switches of all units.
 - o If the remote-sensing operation is needed, use the (+S) terminal of the uppermost unit and the (-S) terminal of the master unit.

893626

- o If the remote-control operation is needed, remote control the master unit.
6. o If OVP function is needed, set each of the master and slave units for the OVP operation.

4-8. Constant-current Charge/Discharge Operation

4-8-1. Constant-current Charge Operation

- o By using the power supply, a battery or an electrolytic capacitor can be charged with a constant current.

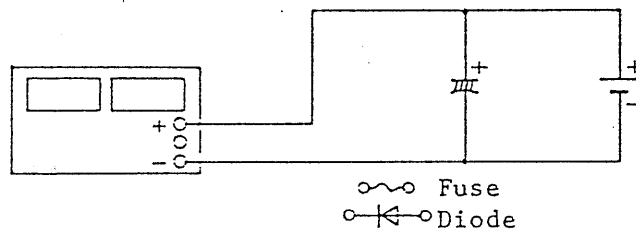

Figure 4-18

- (1) Keeping depressed the current/voltage limit switch, set the charge current with the current setting knob and the charge end voltage with the voltage setting knob.
- (2) Carefully observing the polarity, connect the battery to the power supply (connect the "+" line of the power supply to that of the battery and connect the "-" line of the power supply to that of the battery). If they are connected in the wrong polarity, the reverse current check diode which is connected between the output terminals in the power supply may be damaged. (Although the power supply itself is protected by diode, the load is shorted and it may be damaged. Be sure to connect the wires in the correct polarity. It is most recommendable to connect a fuse and/or diode in series to the load to protect it against inadvertent wrong-polarity connection.)

000000

- (3) Turn on the OUTPUT switch. Charging of the battery with a constant current will start. When the charge end voltage is reached, the power supply is automatically switched into the constant-voltage mode, indicating that the charge operation is over.

- Notes:
1. The power supply is incorporated with a potentiometer burn out protection circuit. Therefore, no problems occur even when the voltage setting potentiometer is set at a voltage lower than that of the load battery or electrolytic capacitor.
 2. At the instant the battery is connected to the power supply, a spark may be generated. This is because the capacitor of the output circuit of the power supply is charged by the current which flows from the battery and the spark is not an abnormal indication. No spark will be generated if the battery is connected to the power supply after making its voltage the same with that of the battery.
 3. If the POWER switch of the power supply is turned off with the load battery or capacitor connected to the power supply, a discharge current of several hundreds milliamperes will flow from the load through the discharge circuit formed in the power supply. If this discharge current is undesirable, connect a switch or a diode in series to the load.

833591

4-8-2. Constant-current Discharge Operation

- o By using the power supply, a battery or an electrolytic capacitor can be discharged with a constant current.

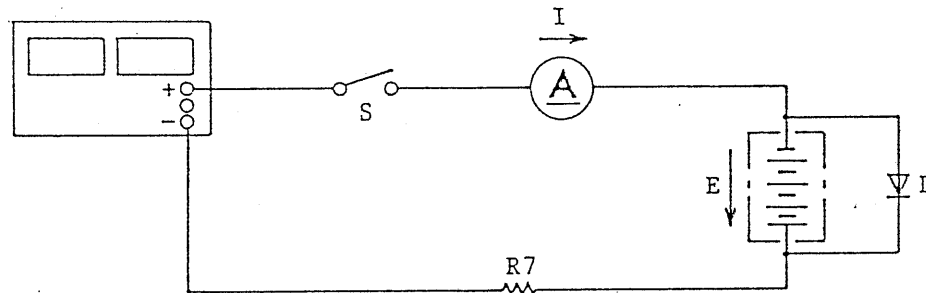

Figure 4-19

E: Battery terminal voltage at the start of discharge [V]

I: Discharge current (constant current) [A]

R7: Load resistor for discharge [Ω] $R7 [\Omega] = \frac{V [V]}{I [A]}$

D: Reverse current check diode

Power dissipation by R7: $P = I^2 \cdot R$ [W]

- (1) Set the output voltage of the power supply with the voltage setting potentiometer at a voltage higher by several volts than the battery terminal voltage. (With this setup, the battery can be discharged to zero volts.)
- (2) Calculate the value of the load resistor R. Select it with a sufficient allowance of wattage.
- (3) Keeping depressed the current/voltage limit switch, set the discharge current with the current setting knob.
- (4) Turn on the OUTPUT switch and close the switch S so that the battery starts discharging with a constant current.
- (5) To stop discharging, open the switch S. Discharging cannot be stopped by turning off the input POWER switch or the OUTPUT switch of the power supply because the discharge current goes on flowing through the diode which is connected in parallel to the output circuit of the power supply.

- Notes:
1. Be sure to connect the load resistor R when using the power supply to discharge a battery. Note that the power supply is damaged if the battery is directly connected to it.
 2. Be sure to connect the reverse current check diode.

803033

SECTION 5. MAINTENANCE

5-1. Inspection

Periodically inspect and service the power supply so that it maintains its initial performance for a long time.

5-1-1. Removing Dust and Dirt

- o When the instrument panels have become dirty, lightly wipe them with a cloth moistened with diluted neutral soapsuds and, then, wipe it with a dry cloth.
- o Do not use benzine or thinner.

5-1-2. Cleaning of Inside

- o To remove the cover, see Figure 5-1.

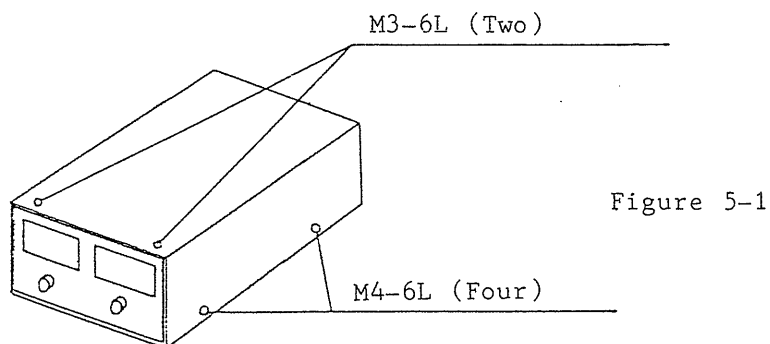

- o Be sure to disconnect the input power cord from the AC power outlet for the sake of safety.
- o Blow away dust collected inside the instrument and in the ventilation holes of the casing, using a compressed air or a vacuum cleaner.

Notes: o Do not open the shield case inside the instrument. (The inside of the shield case is not to be serviced by the user for himself.)

- o Keep your hands off the internal switches.

1243

833684A

5-1-3. Checking the Input Power Cord

- o Check the vinyl sheath for damage, the plug for burning, and the terminal block screws and crimping terminals for loosening.

5-2. Meter Calibration and Adjustment

5-2-1. Calibration of Voltmeter

Connect an external voltmeter of an accuracy of 0.5% or better to the output terminals, set the output voltage at the value indicated in Table 5-1, and calibrate the instrument voltmeter to the same value with the VML control on the service panel.

5-2-2. Calibration of Voltage Limit Switch

The output voltage is shown in Table 5-1. Press the current/voltage limit switch and adjust the VML control on the service panel so that the voltmeter indicates the value shown in Table 5-1.

5-2-3. Calibration of Preset OVP Voltage

Set the output voltage at the value shown in Table 5-1. Gradually lower the OVP voltage (slowly turn counterclockwise the OVP potentiometer using a plain screwdriver) to the point where the OVP circuit trips. Check that the OVP voltage is set at the value shown in Table 5-1.

Adjust the VMO control of the service panel so that the voltmeter indicates the OVP voltage when the OVP preset button is pressed.

5-2-4. Adjustment of Maximum Variable Constant-voltage Range

Connect to the output terminals an external voltmeter of an accuracy of 0.5% or better, set the constant-voltage setting knob in the maximum position (clockwise extreme position), and adjust R257 of PCB A-480 so that the instrument voltmeter reads the value shown in Table 5-1. (See Figure 5-2.)

839635

5-2-5. Calibration of Ammeter

Connect an external ammeter of an accuracy of 0.5% or better to the output circuit, set the output current at the value shown in Table 5-1, and calibrate the instrument ammeter with the AMA control of the service panel.

5-2-6. Calibration of Current Limit Switch

Keeping depressed the current/voltage limit switch, adjust the AML control of the service panel so that the ammeter reads the current limit switch calibration current shown in Table 5-1.

5-2-7. Adjustment of Maximum Variable Constant-current Range

Connect in the output circuit an external ammeter of an accuracy of 0.5% or better, set the constant-current setting knob to the clockwise extreme position, and adjust R211 of PCB A-480 so that the instrument ammeter reads the value shown in Table 5-1. (See Figure 5-2.)

5-2-8. Adjustment of V_{CE} of Series Control Transistor

- (1) Set the input voltage at the rated voltage of the power supply (120 V or 240 V).
- (2) Connect a load and feed the rated current (full load current).
- (3) Connect a mean-value-indicating voltmeter between the collector and emitter of the power transistor. Adjust R264 of PCB A-480 so that the voltmeter reads the value shown in Table 5-1.

833636

Table 5-1

MODEL	PAL 16-40	PAL 35-20
Calibration of voltmeter	16 V	35 V
Calibration of voltage limit switch	16 V	35 V
Calibration of preset OVP	16 V	35 V
Adjustment of maximum variable constant-voltage range (R257)	16.5 V	36 V
Calibration of ammeter	40 A	20 A
Calibration of current limit switch	40 A	20 A
Adjustment of maximum variable constant-current range (R211)	42 A	21 A
Adjustment of V _{CE} of series control transistor (R264)	3.0 V	3.5 V

o Repair Service

When the power supply has failed, please contact your Kikusui agent. As a general rule, the power supply should be repaired by a service organization authorized by Kikusui. The circuits in the shield case must not be subjected to maintenance or repair by the user for himself. (Note that Kikusui may refuse to accept the repair order if the internal circuits have been adjusted or modified by the user for himself.)

833037

830888

POTENTIOMETER (R264) FOR VCE ADJUSTMENT
OF SERIES CONTROL RESISTOR

POTENTIOMETER (R257) FOR ADJUSTMENT OF
MAXIMUM VARIABLE CONSTANT-VOLTAGE RANGE

POTENTIOMETER (R211) FOR ADJUSTMENT OF
MAXIMUM VARIABLE CONSTANT-CURRENT RANGE

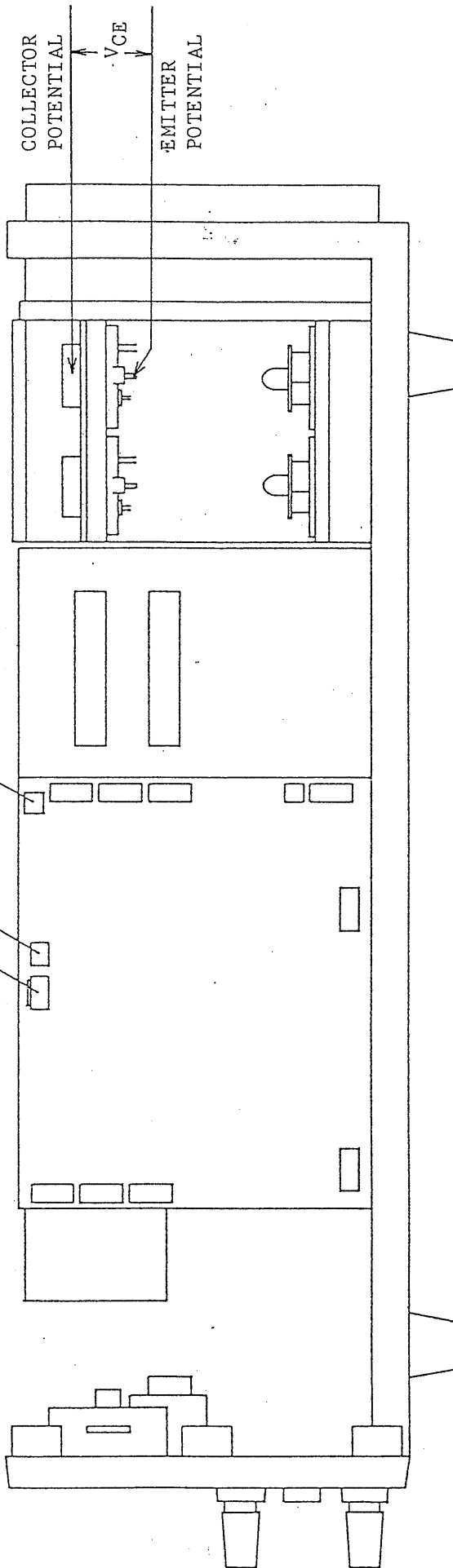
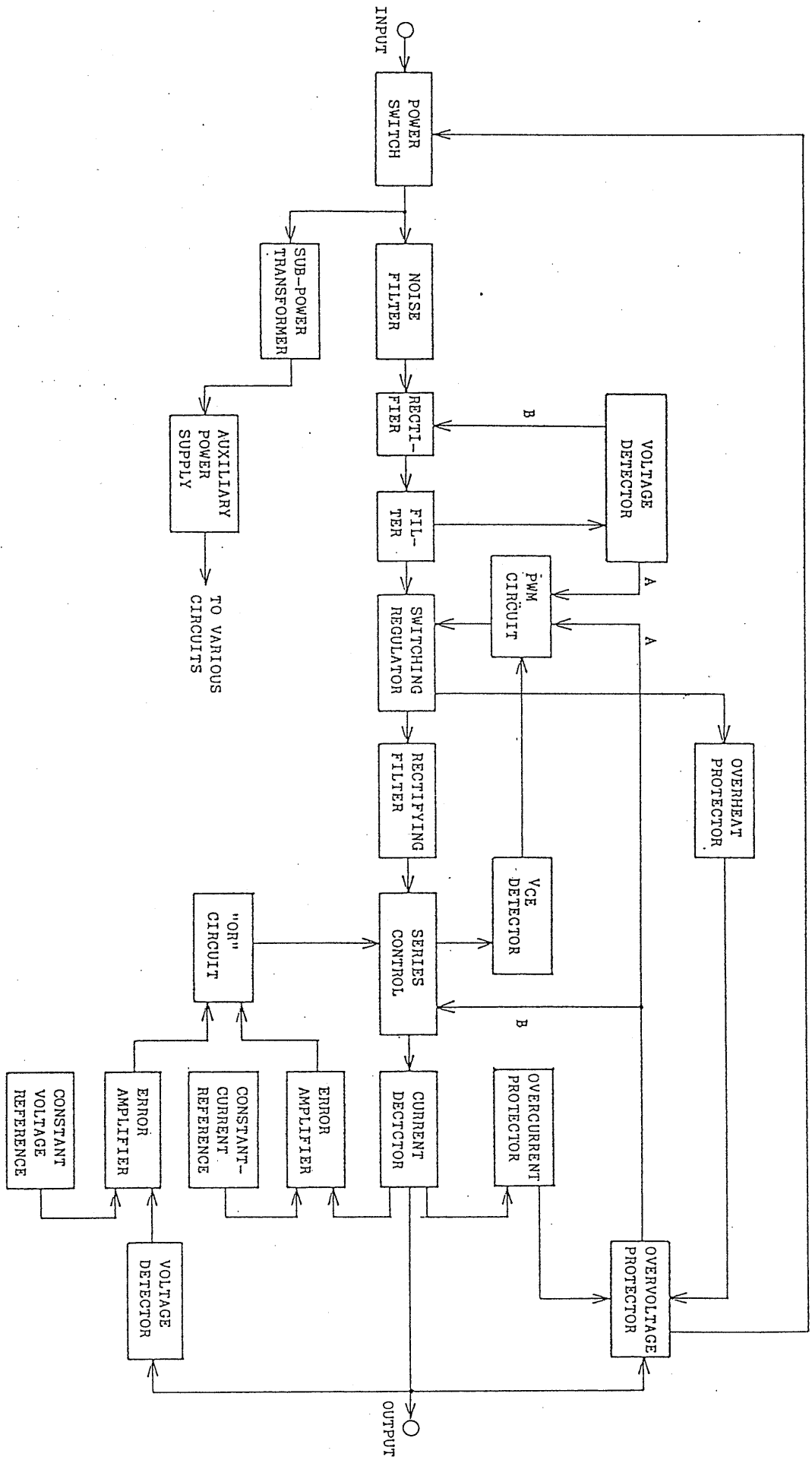

Figure 5-2



Block Diagram

833639